

# LEARNING ABOUT OPTIONS IN FIBER

---

Including

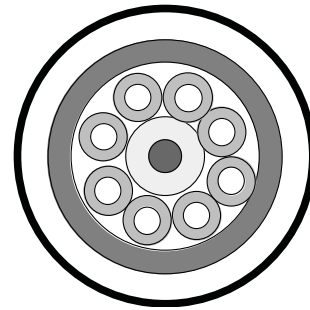

An Introduction

Fiber-Optic Basics

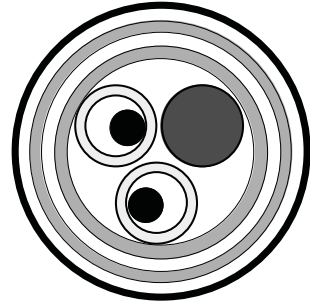

Tables and Terms

Applications

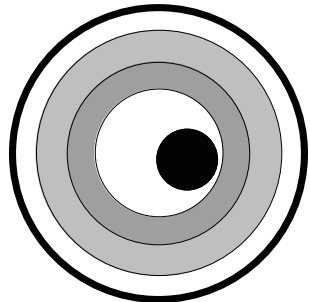

# TABLE OF CONTENTS

---

## SECTION 1

History of Information Transmission .....	1-1
Advantages/Disadvantages of Fiber .....	1-1
Light and Reflection and Refraction .....	1-3

## SECTION 2

The Optical Fiber .....	2-1
The Fiber-Optic Cable .....	2-7
Sources.....	2-12
Detectors .....	2-13
Transmitters and Receivers.....	2-15
Connectors and Splices .....	2-17
Couplers and Networks .....	2-25
WDM .....	2-26
Optical Switch.....	2-27

## SECTION 3

Tables .....	3-1
Glossary of Terms.....	3-5

## SECTION 1—INTRODUCTION TO FIBER

---

### HISTORY

The use of light for the transmission of information is far from a new idea. Paul Revere's lanterns were used to signal the approach of the British. And it was Alexander Graham Bell's experiments over a century ago that led to his development of the photophone, a device that carried speech from one point to another by means of vibrating mirrors and a beam of sunlight.

Although never a commercial success, it nevertheless demonstrated the feasibility of lightwave communications. However the technique was shunted aside and virtually forgotten for almost another hundred years.

It probably would have remained in limbo had it not been for the appearance of a device called the laser.

Laser is an acronym for **L**ight **A**mplification by **S**timulated **E**mission of **R**adiation.

Simply described, the laser is a device that produces a unique kind of radiation — an intensely bright light which can be focused into a narrow beam of precise wavelength. The tremendous energies of the laser stem from the fact that it produces what is called coherent light .

The light that comes from a candle or an incandescent bulb is called incoherent light. It's made up of many different, relatively short wavelengths (colors) which together appear white. They are sent out in brief bursts of energy at different times and in different directions. These incoherent light waves interfere with each other, thus their energy is weakened, distorted, and diffused.

The laser, on the other hand, emits light waves that all have the same wavelength, are in phase, and can be sharply focused to travel in the same direction over long distances with almost no dispersion or loss of power.

Lasers provide radiation at optical and infrared frequencies. With lasers (and associated electronics) it became possible to perform at optical frequencies the electronics functions that engineers were accustomed to performing at conventional radio and microwave frequencies. Thus lasers promised the ability to channel signals with very high information rates along an extremely narrow path.

### INFORMATION TRANSMISSION

Fiber optics is a relatively new technology that uses rays of light to send information over hair-thin fibers at blinding speeds. These fibers are used as an alternative to conventional copper wire in a variety of applications such as those associated with security, telecommunications, instrumentation and control, broadcast or audio/visual systems.

Today the ability to transmit huge amounts of information along slender strands of high-purity glass optical fiber with the speed of light has revolutionized communications.

The large signal-carrying capacity of optical fibers makes it possible to provide not only many more, but much more sophisticated signals than could ever be handled by a comparable amount of copper wire.

### ADVANTAGES/DISADVANTAGES

The advantages of fiber over copper include:

- **Small Size:** A 3/8-inch (12 pair) fiber/cable operating at 140 mb/s can handle as many voice channels as a 3-inch diameter copper (900) twisted-pair cable.
- **Light Weight:** The same fiber-optic cable weighs approximately 132 lbs per kilometer. The twisted pair cable weighs approximately 16,000 lbs.
- **High Bandwidth:** Fiber optics has been bandwidth tested at over 4-billion bits per second over a 100 km (60 miles) distance. Theoretical rates of 50-billion bits are obtainable.
- **Low Loss:** Current single-mode fibers have losses as low as .2 dB per km. Multimode losses are down to 1 dB (at 850 or 1300 nm). This creates opportunities for longer distances without costly repeaters.
- **Noise Immunity:** Unlike wire systems, which require shielding to prevent electromagnetic radiation or pick-up, fiber-optic cable is a dielectric and is not affected by electromagnetic or radio frequency interference. The potential for lower bit error rates can increase circuit efficiency.

## SECTION 1—INTRODUCTION TO FIBER

---

- **Transmission Security:** Because the fiber is a dielectric the fiber does not radiate electromagnetic pulses, radiation, or other energy that can be detected. This makes the fiber/cable difficult to find and methods to tap into fiber create a substantial system signal loss.
- **No Short Circuits:** Since the fiber is glass and does not carry electrical current, radiate energy, or produce heat or sparks, the data is kept within the fiber medium.
- **Wide Temperature Range:** Fibers and cables can be manufactured to meet temperatures from -40°F to +200°F. Resistance to temperatures of 1,000°F have been recorded.
- **No Spark or Fire Hazard:** Fiber optics provides a path for data without transmitting electrical current. For applications in dangerous or explosive environments, fiber provides a safe transmission medium.
- **Fewer Repeaters:** Few repeaters, if any, are required because of increased performance of light sources and continuing increases in fiber performance.
- **Stable Performance:** Fiber optics is affected less by moisture which means less corrosion and degradation. Therefore, no scheduled maintenance is required. Fiber also has greater temperature stability than copper systems.
- **Topology Compatibility:** Fiber is suitable to meet the changing topologies and configurations necessary to meet operation growth and expansions. Technologies such as wavelength division multiplexing (WDM), optical multiplexing, and drop and insert technologies are available to upgrade and reconfigure system designs.
- **Decreasing Costs:** Costs are decreasing, larger manufacturing volumes, standardization of common products, greater repeater spacing, and proven effectiveness of older “paid for” technologies such as multimode.
- **Nonobsolescence:** Expansion capabilities beyond current technologies using common fibers and transmission techniques.
- **Material Availability:** Material (silica glass) required for the production of fiber is readily available in a virtually unending supply.

The few disadvantages of fiber include:

- **Cost:** Individual components, such as connectors, light sources, detectors, cable and test equipment, may be relatively expensive when compared directly to equivalent items in a copper system.
- **Taps:** Drop points must be planned because optical splitters or couplers are much more difficult to install after the system is in.
- **Fear of New Technologies:** Because the technology is considered to be new, people are reluctant to change and use these methods. The use of metric and physics is still an unfamiliar area to many established users.

### LIGHT

Light is electromagnetic energy, as are radio waves, radar, television and radio signals, x-rays, and electronic digital pulses. Electromagnetic energy is radiant energy that travels through free space at about 300,000/km/s or 186,000 miles/s.

An electromagnetic wave consists of oscillating electric and magnetic fields at right angles to each other and to the direction of propagation. Thus, an electromagnetic wave is usually depicted as a sine wave. The main distinction then between different waves lies in their frequency or wavelength. In electronics we customarily talk in terms of frequency. In fiber optics, however, light is described by wavelength. Frequency and wavelength are inversely related.

Electromagnetic energy exists in a continuous range from subsonic energy through radio waves, microwaves, gamma rays, and beyond. This range is known as the electromagnetic spectrum.

It seems to be well understood that glass optical fiber does not conduct electrons as wire does, or channel radio-frequency signals as coaxial cable does. However, many are unclear about how the light signals are transmitted and how light acts as a messenger for video, audio, and data over fiber.

## SECTION 1—INTRODUCTION TO FIBER

### REFLECTION AND REFRACTION

Optical fiber transmits light by a law of physics known as the principle of total internal reflection. This principle was discovered by a British scientist named John Tyndall in the mid-1800s. He used it to demonstrate a way to confine light and actually bend it around corners. His experiments directed a beam of light out through a hole in the side of a bucket of water. He was able to demonstrate how the light was confined to the curved stream of water, and how the water's changing path redirected the path of light.

Total *internal* reflection is even more efficient than *mirrored* reflection; it reflects more than 99.9 percent of the light.

The quantifiable physical property of a transparent material that relates to total internal reflection is its *refractive index*. Refractive index is defined as the ratio of the speed of light in a vacuum to the speed of light in a specific material.

Light travels fastest through a vacuum. As it starts to travel through denser material, it slows down a little. What is commonly called the speed of light is actually the velocity of electromagnetic energy in a vacuum such as space. Light travels at slower velocities in other materials such as glass.

Light traveling from one material to another changes speed, which results in light changing its direction of travel. This deflection of light is called *refraction*. In addition, different wavelengths of light travel at different speeds in the same material. The variation of velocity with wavelength plays an important role in fiber optics.

White light entering a prism contains all colors. The prism refracts the light and it changes speed as it enters. Because each wave changes speed differently, each is refracted differently. Red light deviates the least and travels the fastest. Violet light deviates the most and travels the slowest.

The light emerges from the prism divided into the colors of the rainbow. As can be seen in Figure 1-1 refraction occurs at the entrance and at the exit of the prism. The amount that a ray of light is refracted depends on the refractive indices of the two materials. Figure 1-2 illustrates several important terms required to understand light and its refraction.

Figure 1-1—Refraction and a Prism

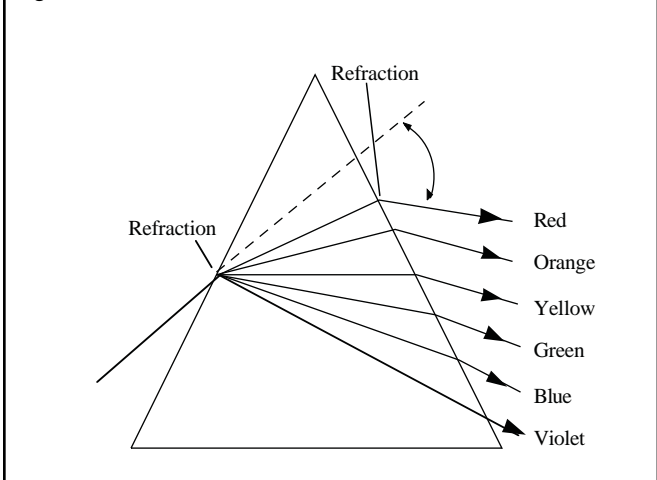
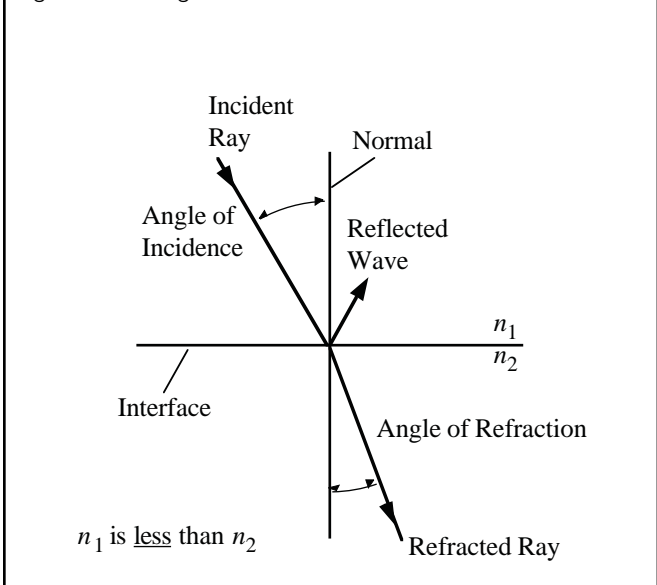

Figure 1-2—Angles of Incidence and Refraction



- The normal is an imaginary line perpendicular to the interface of the two materials.
- The angle of incidence is the angle between the incident ray and the normal.
- The angle of refraction is the angle between the refracted ray and the normal.

Light passing from a lower refractive index to a higher one is bent toward the normal. But light going from a higher index to a lower one refracts away from the normal, as shown in Figure 1-3.

## SECTION 1—INTRODUCTION TO FIBER

Figure 1-3—Refraction

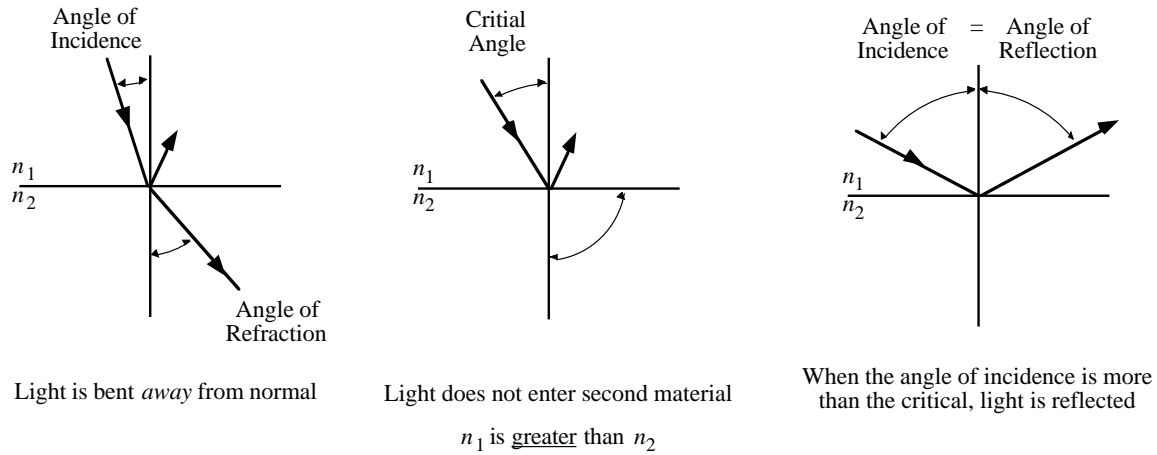

As the angle of incidence increases, the angle of refraction of  $90^\circ$  is the critical angle. If the angle of incidence increases past the critical angle, the light is totally reflected back into the first material so that it doesn't enter the second material. The angles of incidence and reflection are equal.

Thus:

- Light is electromagnetic energy with a higher frequency and shorter wavelength than radio waves.
- Light has both wave-like and particle-like characteristics.
- When light meets a boundary separating materials of different refractive indices, it is either refracted or reflected.

## SECTION 2—FIBER-OPTIC BASICS

### THE OPTICAL FIBER

#### BASIC FIBER CONSTRUCTION

Optical fiber consists of a thin strand (or core) of optically pure glass surrounded by another layer of less pure glass (the cladding). The inner core is the light-carrying part. The surrounding cladding provides the difference in refractive index that allows total internal reflection of light through the core. The index of the cladding is less than 1 percent lower than that of the core.

Most fibers have an additional coating around the cladding. This coating, usually one or more layers of polymer, protects the core and cladding from shocks that might affect their optical or physical properties. The coating has no optical properties affecting the propagation of light within the fiber. Thus the buffer coating serves as a shock absorber.

Figure 2-1 shows the idea of light traveling through a fiber. Light injected into the fiber and striking the core-to-cladding interface at greater than the critical angle reflects back into the core. Since the angles of incidence and reflection are equal, the reflected light will again be reflected. The light will continue zig zagging down the length of the fiber.

Light, however, striking the interface at less than the critical angle passes into the cladding where it is lost over distance. The cladding is usually inefficient as a light carrier, and light in the cladding becomes attenuated fairly rapidly.

Notice also in Figure 2-1 that the light is refracted as it passes from air into the fiber. Thereafter, its

propagation is governed by the indices of the core and cladding (and by Snell's law.) Refer to section 3, Glossary of Terms, for a definition of Snell's Law.

The specific characteristics of light propagation through a fiber depends on many factors including: The size of the fiber; the composition of the fiber; and the light injected into this fiber. An understanding of the interplay between these properties will clarify many aspects of fiber optics.

Fiber is basically classified into three groups:

- Glass (silica) which includes single-mode step index fibers, multimode graded index, and multimode step index.
- Plastic clad silica (PCS).
- Plastic.

Most optical fibers for telecommunications are made 99 percent of silica glass, the material from which quartz and sand are formed. Figure 2-1 on the previous page shows a fiber, which consists of an inner core (about 8 to 100 micrometers, or 0.0003 to 0.004 inches, in diameter), a cladding (125 to 140 micrometers outer diameter) and a buffer jacket for protection.

The clad is made of glass of a slightly different formula. This causes light entering the core at one end of the fiber to be trapped inside, a phenomenon called internal reflection. The light hits the boundary between the core and the cladding bouncing off the cladding much like a billiard ball and at the same angle as it travels down the fiber.

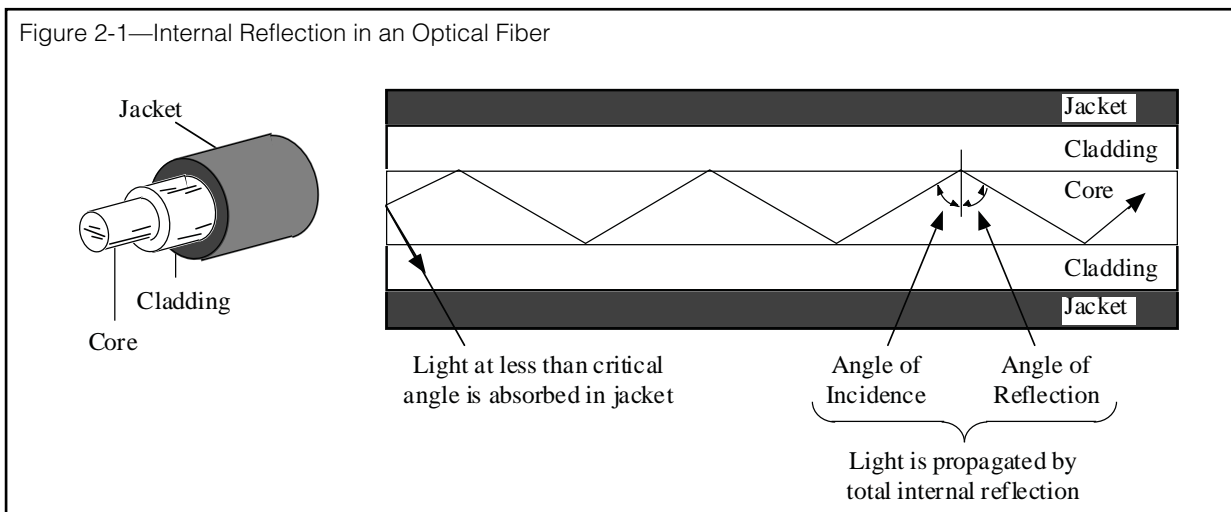

## SECTION 2—FIBER OPTIC BASICS

Plastic fibers are much larger in diameter and can only be used for slow-speed, short-distance transmission. Plastic-clad silica (PCS) fibers, featuring a glass core with a plastic cladding, come between glass and plastic fibers in size and performance. Plastic and PCS fibers cost less than silica glass fibers, but they are also less efficient at transmitting light. For this reason, they are being used in cars, sensors, and short-distance data-communications applications.

There are other types of fiber emerging on the marketplace, particularly suited for specialized uses. An example would be fluoride fibers which are being developed for medical and long-haul telecommunications. Medical applications for fiber include transmitting power from a laser to destroy arterial blockages or cancer masses. Since fibers are extremely narrow and flexible, they can be threaded through human arteries to locate precise trouble areas, and in some cases may eliminate the need for surgery.

### MODE

James Clerk Maxwell, a Scottish physicist in the last century, first gave mathematical expression to the relationship between electric and magnetic energy. Mode is a mathematical and physical concept describing the propagation of electromagnetic waves through media. In its mathematical form, mode theory derives from Maxwell's equations. He showed that they were both a single form of electromagnetic energy, not two different forms as was then believed. His equations also showed that the propagation of this energy followed strict rules.

A mode is simply a path that a light ray can follow in traveling down a fiber. The number of modes

supported by a fiber ranges from one to over 100,000. Thus a fiber provides a path of travels for one or thousands of light rays, depending on its size and properties.

### REFRACTIVE INDEX PROFILE

This term describes the relationship between the indices of the core and the cladding. Two main relationships exist: Step index and graded index. The step-index fiber has a core with a uniform index throughout. The profile shows a sharp step at the junction of the core and cladding. In contrast, the graded index has a nonuniform core. The index is highest at the center and gradually decreases until it matches that of the cladding. There is no sharp break between the core and the cladding.

### Step Index

The multimode step-index fiber is the simplest type. It has a core diameter from 100 to 970  $\mu\text{m}$ , and it includes glass, PCS, and plastic constructions. As such, the step-index fiber is the most wide ranging, although not the most efficient in having high bandwidth and low losses.

### Graded Index

A graded-index fiber is one where the refractive index of the fiber decreases radically towards the outside of the core. During the manufacturing process, multiple layers of glass are deposited on the preform in a method where the optical index change occurs. (Refer Figure 2-3 next page.)

As the light ray travels through the core, the fastest index is the higher or outer area in a graded-index core. (Refer Figure 2-4 next page.)

Figure 2-2—Plastic-Clad Silica Fiber

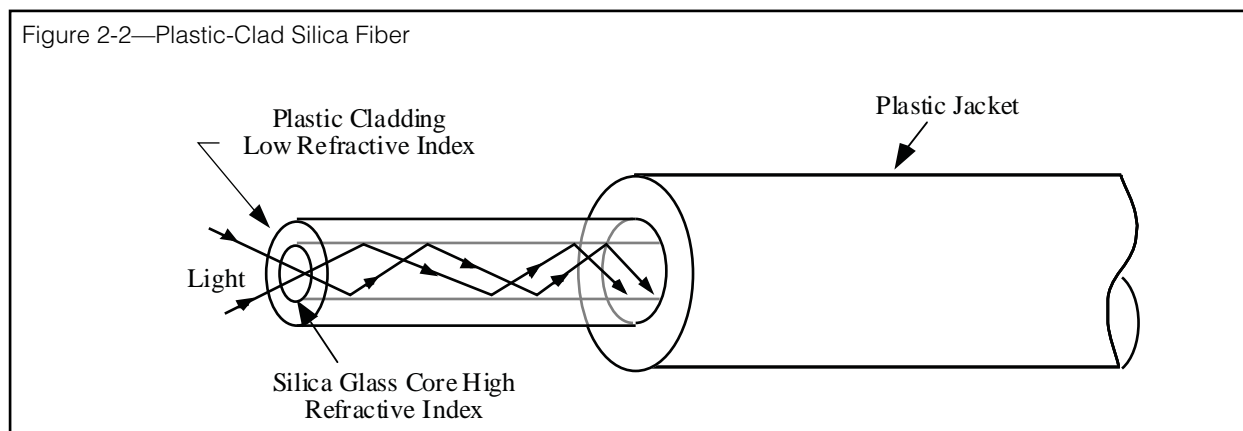

## SECTION 2—FIBER-OPTIC BASICS

The center, or axial mode would be the slowest mode in the graded-index fiber (Figure 2-5). In this circumstance, a mode would slow down when passing through the center of the fiber and accelerate when passing through the outer areas of the core. This is designed to allow the higher order modes to arrive at approximately the same time as an axial or lower order mode. This allows the multimode graded-index fibers to transmit as far as 15-20 kilometers without great pulse spreading. Within these classifications there are three types of fiber:

- Multimode step-index.
- Multimode graded-index.
- Single-mode step-index.

### STEP INDEX

#### Multimode Step-Index Fiber

- Bandwidth of 10 MHz/km
- Loss of 5-20 dB/km.
- Large cores of 200 to 1000 microns.
- Cladding OD up to 1035 microns.
- Is effective with low-cost LEDs
- Limited transmission distances.
- Transmits at 660-1060 wavelengths.

#### Single-Mode Step Index Fiber

- High bandwidth applications (4 GHz).
- Low losses, typically .3 dB to .5 dB/km.
- Core area of 8 to 10 microns.
- Cladding OD of 125 microns.
- Transmits at 1300 nm and 1550 nm wavelengths.
- Higher costs for connectors, splices, and test equipment, and transmitters/receivers.

#### Plastic Step-Index Fiber

- Lower bandwidth 5 MHz over distances of 200 feet.
- Losses of 150-250 dB/km.
- Core area from 1000-3000 microns.
- Cladding up to 3000 microns.
- Uses LEDs to transmit data very well.
- Very easy to connectorize.
- Inexpensive.
- Operates best at 660 nm red wavelength.

Figure 2-3—Graded Index Fiber

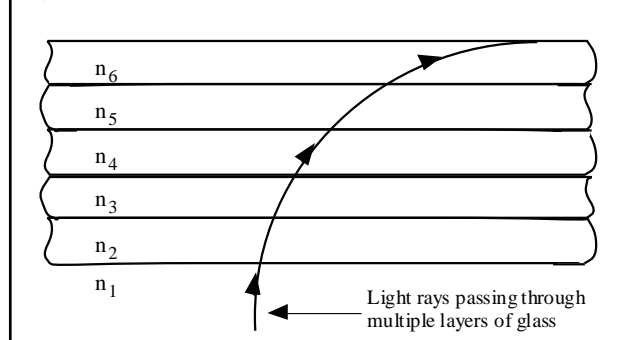

Figure 2-4—High-Order Mode

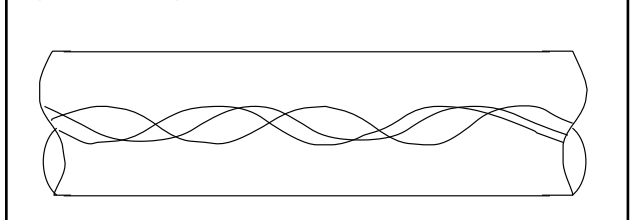
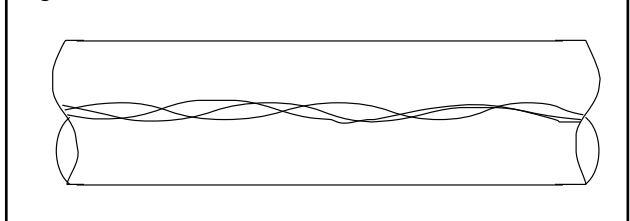

Figure 2-5—Low-Order Mode



#### Plastic-Clad Silica Step-Index Fiber

- Bandwidth up to 25 MHz/km
- Losses of 6-10 dB/km.
- Glass core from 200-600 microns.
- Plastic cladding OD to 1000 microns.
- LEDs used to transmit data. Difficult to connectorize and unstable.
- Very resistant to radiation.
- Operates at 660-1060 wavelengths.

### GRADED INDEX

#### Multimode Graded-Index Fiber

- Bandwidths up to 600 MHz/km.
- Losses of 2 to 10 dB/km.
- Cores of 50/62.5/85/100 microns.
- Cladding OD of 125 and 140 microns.
- Is effective with laser or LED sources.
- Medium- to low-cost for components, test equipment, and transmitters and receivers.

## SECTION 2—FIBER-OPTIC BASICS

- Has distance limitations due to higher loss and pulse spreading.
- Transmits at 820-850 nm, 1300 nm, and 1550 nm wavelengths.
- Easy to splice and connectorize.

### MULTIMODE AND SINGLE-MODE FIBER

Two general types of fiber have emerged to meet user requirements: *multimode* and *single mode*. In optical terminology, “mode” can be thought of as a ray of light.

In multimode fiber many modes, or rays, are transmitted, whereas in single-mode fiber only one mode of light can travel in the core. Refer to Figure 2-6 where the core diameters of these two types of fiber have been compared to the diameter of a single human hair.

#### Multimode

Multimode fiber’s larger core (diameter in the 50- $\mu\text{m}$  to more than 1000- $\mu\text{m}$  range) captures hundreds of rays from the light source, entering the core at many different angles. Some of these rays exceed the critical angle of incidence and are lost without penetrating the fiber.

Of the rays that are captured by the core, some travel a direct path parallel to the length of the fiber. Modes that enter at a steeper angle travel a longer, circuitous route, crisscrossing the core’s diameter as they travel down the fiber. Because of these different routes, some parts of the light pulse reach the far end sooner than other parts of the same light pulse.

These differences result in pulse broadening (or spreading) which requires more space between pulses, thereby limiting the speed at which pulses can be introduced into the fiber, and limiting the bandwidth or information-carrying capacity of multimode fiber.

Multimode fibers were developed first, and they have been installed in many long-distance telecommunications systems. In the past few years, however, single-mode technology has improved to the point where these smaller fibers are made as easily and as cheaply as multimode fibers.

Figure 2-6—Core Diameter of Fiber

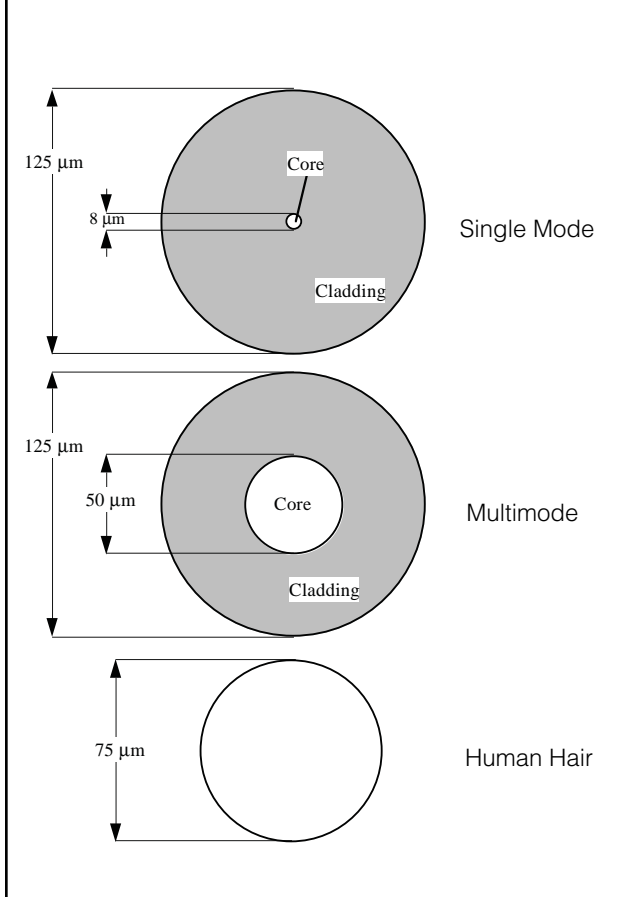

Multimode fiber’s significantly larger core (more than five times the diameter of a single-mode core) has certain advantages. It is easier to align core regions for splicing and for attaching connectors, and it captures more light from lower cost sources, such as from LEDs rather than lasers. Thus multimode is usually preferred for systems that have many connectors or joints, and where distance or capacity is not a factor.

Further, methods can be devised for increasing multimode fiber’s information-carrying capacity, such as transmitting on multiple wavelengths of light. This technique is known as wavelength division multiplexing or WDM.

#### Single-Mode

Single-mode fiber overcomes the bandwidth shortcomings of multimode. Single-mode fiber has a much smaller core diameter (typically 8  $\mu\text{m}$  to 10  $\mu\text{m}$ ) allowing a very narrow beam from a single source to pass through it with a minimum of pulse dispersion. The cladding diameter, however,

## SECTION 2—FIBER-OPTIC BASICS

---

remains at the industry standard of 125 microns for purposes of connecting and splicing.

With only one mode it is easier to maintain the integrity of each light pulse. The pulses can be packed much more closely together in time, giving single-mode fiber much larger channel capacity.

Refer to section 3, References, Tables A and B for charts offering fiber comparisons.

### DISPERSION

Dispersion is the spreading of a light pulse as it travels down the length of an optical fiber. Dispersion limits the bandwidth (or information-carrying capacity) of a fiber. There are three main types of dispersion: Modal, material, and waveguide.

### Modal Dispersion

Modal dispersion occurs only in multimode fiber. Multimode fiber has a core diameter in the 50- $\mu\text{m}$  to more than 1000- $\mu\text{m}$  range. The large core allows many modes of light propagation. Since light reflects differently for different modes, some rays follow longer paths than others. (Refer to page 2-3, Figures 2-3, 2-4 and 2-5.)

The lowest order mode, the axial ray traveling down the center of the fiber without reflecting, arrives at the end of the fiber before the higher order modes that strike the core-to-cladding interface at close to the critical angle and, therefore, follow longer paths.

Thus, a narrow pulse of light spreads out as it travels through the fiber. This spreading of a light pulse is called modal dispersion. There are three ways to limit modal dispersion:

- Use single-mode fiber since its core diameter is small enough that the fiber propagates only one mode efficiently.
- Use a graded-index fiber so that the light rays that follow longer paths also travel at a faster average velocity and thereby arrive at the other end of the fiber at nearly the same time as rays that follow shorter paths.
- Use a smaller core diameter, which allows fewer modes.

### Material Dispersion

Different wavelengths (colors) also travel at different velocities through a fiber, even in the same mode (refer to earlier discussions on Index of Refraction). Each wavelength, however, travels at a different speed through a material, so the index of refraction changes according to wavelength. This phenomenon is called material dispersion since it arises from the material properties of the fiber.

Material dispersion is of greater concern in single-mode systems. In multimode systems, modal dispersion is usually significant enough that material dispersion is not a problem

### Waveguide Dispersion

Waveguide dispersion, most significant in a single-mode fiber, occurs because optical energy travels at slightly different speeds in the core and cladding. This is because of the slightly different refractive indices of the materials.

Altering the internal structure of the fiber allows waveguide dispersion to be substantially changed, thus changing the specified overall dispersion of the fiber.

### BANDWIDTH VS. DISPERSION

Manufacturers of multimode offerings frequently do not specify dispersion, rather they specify a measurement called bandwidth (which is given in megahertz/kilometers).

For example, a bandwidth of 400 MHz/km means that a 400-MHz signal can be transmitted for 1 km. It also means that the product of the frequency and the length must be 400 or less ( $\text{BW} \times \text{L} = 400$ ). In other words, you can send a lower frequency a longer distance: 200 MHz for 2 km; 100 MHz for 4 km; or 50 MHz for 8 km.

Conversely, a higher frequency can be sent a shorter distance: 600 MHz for 0.66 km; 800 MHz for 0.50 km; or 1000 MHz for 0.25 km

Single-mode fibers, on the other hand, are specified by dispersion. This measurement is expressed in picoseconds per kilometer per nanometer of source spectral width (ps/km/nm).

In other words, for single-mode fiber dispersion is

## SECTION 2—FIBER-OPTIC BASICS

most affected by the source's spectral width; the wider the source width (the more wavelengths injected into the fiber), the greater the dispersion.

### ATTENUATION

Attenuation is the loss of optical power as light travels through fiber. Measured in decibels per kilometer, it ranges from over 300 dB/km for plastic fibers to around 0.21 dB/km for single-mode fiber.

Attenuation varies with the wavelength of light. In fiber there are two main causes: Scattering and Absorption

### Scattering

Scattering (Figure 2-7), the more common source of attenuation in optical fibers, is the loss of optical energy due to molecular imperfections or lack of optical purity in the fiber and from the basic structure of the fiber.

Scattering, does just what its name implies. It scatters the light in all directions including back to the optical source. This light reflected back is what allows optical time domain reflectometers (OTDRs) to measure attenuation levels and optical breaks

### Absorption

Absorption (Figure 2-8) is the process by which impurities in the fiber absorb optical energy and dissipate it as a small amount of heat, causing the light to become "dimmer." The amount converted to heat, however, is very minor.

### Microbend Loss

Microbend loss (Figure 2-9) results from small variations or "bumps" in the core-to-cladding interface. Transmission losses increase due to the fiber radius decreasing to the point where light rays begin to pass through the cladding boundary. This causes the fiber rays to reflect at a different angle, therefore creating a circumstance where higher order modes are refracted into the cladding to escape. As the radius decreases, the attenuation increases.

Fibers with a graded index profile are less sensitive to microbending than step-index types. Fibers with larger cores and different wavelengths can exhibit different attenuation values.

Figure 2-7—Scattering

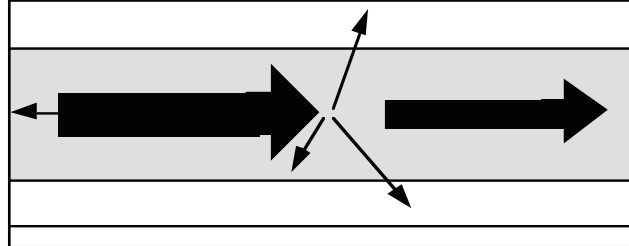

Figure 2-8—Absorption

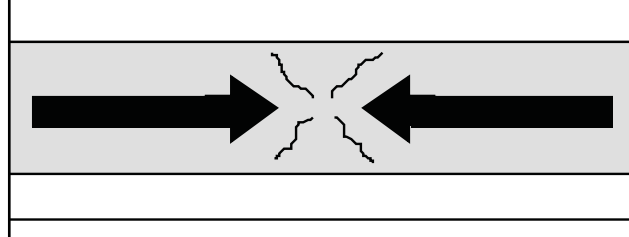

Figure 2-9—Microbend

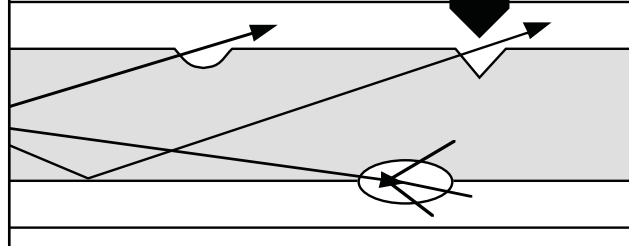
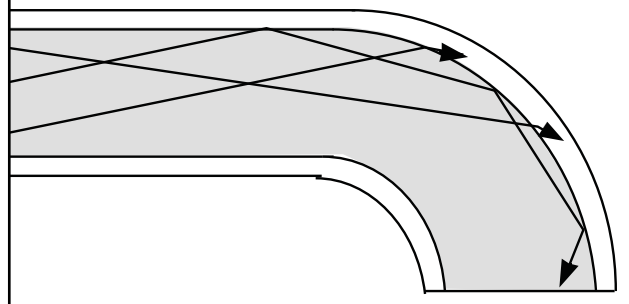

Figure 2-10—Macrobend



### Macrobend Loss

Macrobend losses (Figure 2-10) are caused by deviations of the core as measured from the axis of the fiber. These irregularities are caused during the manufacturing procedures and should not be confused with microbends.

## SECTION 2—FIBER-OPTIC BASICS

---

### NUMERICAL APERTURE

The numerical aperture (NA), or light-gathering ability of a fiber, is the description of the maximum angle in which light will be accepted and propagated within the core of the fiber. This angle of acceptance can vary depending upon the optical characteristics of the indices of refraction of the core and the cladding.

If a light ray enters the fiber at an angle which is greater than the NA or critical angle, the ray will not be reflected back into the core. The ray will then pass into the cladding becoming a cladding mode, eventually to exit through the fiber surface. The NA of a fiber is important because it gives an indication of how the fiber accepts and propagates light. A fiber with a large NA accepts light well; a fiber with a low NA requires highly directional light.

Fibers with a large NA allow rays to propagate at higher or greater angles. These rays are called higher order modes. Because these modes take longer to reach the receiver, they decrease the bandwidth capability of the fiber and will have higher attenuation.

Fibers with a lower NA, therefore, transmit lower order modes with greater bandwidth rates and lower attenuation.

Manufacturers do not normally specify NA for single-mode fibers because NA is not a critical parameter for the system designer or user. Light in a single-mode fiber is not reflected or refracted, so it does not exit the fiber at angles. Similarly, the fiber does not accept light rays at angles within the NA and propagate them by total internal reflection. Thus NA, although it can be defined for a single-mode, is essentially meaningless as a practical characteristic.

### FIBER STRENGTH

One expects glass to be brittle. Yet, a fiber can be looped into tight circles without breaking. It can also be tied into loose knots (pulling the knot tight will break the fiber). Tensile strength is the ability of a fiber to be stretched or pulled without breaking.

The tensile strength of a fiber exceeds that of a steel filament of the same size. Further, a copper wire must have twice the diameter to have the same tensile strength as fiber.

As discussed under "Microbend Loss," the main cause of weakness in a fiber is microscopic cracks on the surface, or flaws within the fiber. Defects can grow, eventually causing the fiber to break.

### BEND RADIUS

Even though fibers can be wrapped in circles, they have a minimum bend radius. A sharp bend will snap the glass. Bends have two other effects:

- They increase attenuation slightly. This effect should be intuitively clear. Bends change the angles of incidence and reflection enough that some high-order modes are lost (similarly to microbends).
- Bends decrease the tensile strength of the fiber. If pull is exerted across a bend, the fiber will fail at a lower tensile strength than if no bend were present.

### FIBER-OPTIC CABLE

#### CABLE CHARACTERISTICS

Fiber-optic cable is jacketed glass fiber. In order to be usable in fiber-optic systems, the somewhat fragile optical fibers are packaged inside cables for strength and protection against breakage, as well as against such environmental hazards as moisture, abrasion, and high temperatures.

Packaging of fiber in cable also protects the fibers from bending at too sharp an angle, which could result in breakage and a consequent loss of signal.

Multiconductor cable is available for all designs and can have as many as 144 fibers per cable. It is noteworthy that a cable containing 144 fibers can be as small as .75 inches in diameter.

In addition to the superior transmission capabilities, small size, and weight advantages of fiber-optic cables, another advantage is found in the absence of electromechanical interference. There are no metallic conductors to induce crosstalk into the system. Power influence is nonaffecting, and security breaches of communications are (at this time) very difficult due to the complexities of tapping optical fiber.

## SECTION 2—FIBER-OPTIC BASICS

### MAIN PARTS OF A FIBER-OPTIC CABLE

The creation of fiber-optic cables involves placing several fibers together in a process that involves use of strength members and insulated (buffered) conductors. When a number of optical fibers are placed into a single cable, they are frequently twisted around a central passive support (strength member) which serves to strengthen the cable.

Although fiber-optic cable comes in many varieties, most have the following elements in common:

- Optical fiber (core and cladding, plus coating).
- Buffer.
- Strength member.
- Jacket.

Previous sections have dealt with fiber, so only the remaining three items will be dealt with now.

Figure 2-11—Main Parts for a Fiber-Optic Cable

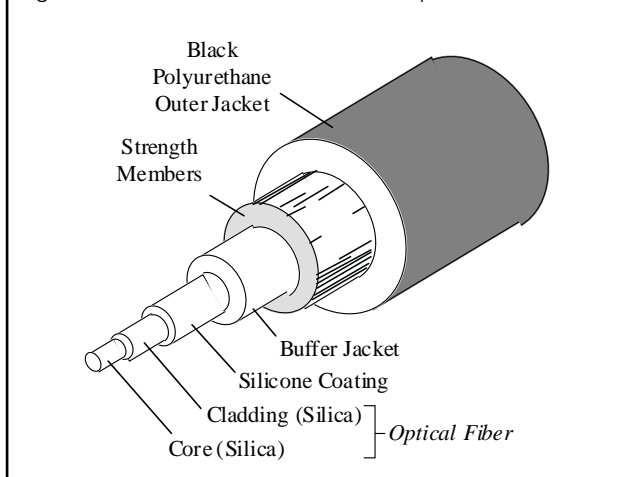

### Buffer

Fiber coating, or the buffer, serves three purposes: (1) Protection of the fiber surface from mechanical damage; (2) isolation of the fiber from the effects of microbends; and (3) as a moisture barrier.

The outer layer, or secondary coating, is the tough material that protects the fiber surface from mechanical damage during handling and cabling operations. The inner, or primary coating, is a material designed to isolate the fiber from damage from microbending. Both layers obviously serve as moisture barriers.

With the exception of abrasion, uncoated fiber is virtually unaffected by many environments. Because of this, most environmental tests are designed to evaluate coating performance over time.

The simplest buffer is the plastic coating applied by the fiber manufacturer to the cladding. An additional buffer is added by the cable manufacturer. The cable buffer is one of two types: *loose buffer* or *tight buffer*.

Figure 2-12—Loose and Tight Buffers

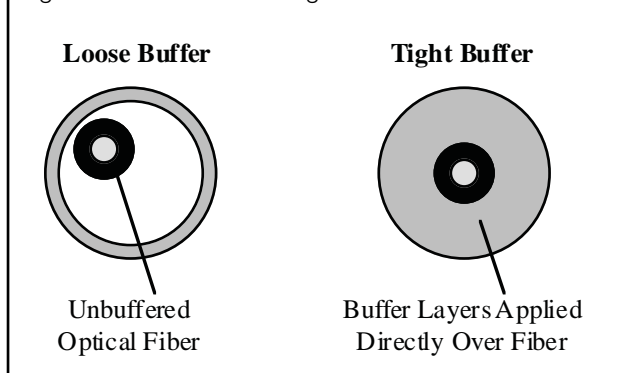

The *tight buffer* design features one or two layers of protective coating placed over the initial fiber coating which may be on an individual fiber basis, or in a ribbon structure. The ribbon design typically features 12 fibers placed parallel between two layers of tape with the ribbons lying loosely within the cable core.

An advantage to the tight buffer is that it is more flexible than loose and allows tighter turn radii. This can make tight-tube buffers useful for indoor applications where temperature variations are minimal and the ability to make tight turns inside walls is a desirable feature.

The *loose buffer* design features fibers placed into a cavity which is much larger than the fiber with its initial coating, such as a buffer tube, envelope, or slotted core. This allows the fiber to be slightly longer than its confining cavity, and allows movement of the fiber within the cable to relieve strain during cabling and field-placing operations.

Individual tight-buffered fiber cables are not generally used in applications subjected to temperature changes due to the added attenuation caused by the strain that is placed on fiber during the cabling process and the contraction differences of the coating material and glass fibers when subjected to these changes.

## SECTION 2—FIBER-OPTIC BASICS

In loose-buffer tube designs, the fiber tube is usually filled with a viscous gel compound which repels water. Slotted, or envelope designs are usually filled with a water-repellent powder. Although water does not affect the transmission properties of optical fiber, the formation of ice within the cable will cause severe microbending and added dB loss to the system.

A comparison of loose tube features to tight tube is provided in section 3, Table C.

### Strength Member

Strength members add mechanical strength to the fiber. During and after installation, the strength members handle the tensile stresses applied to the cable so that the fiber is not damaged.

The most common strength members are of Kevlar aramid yarn, steel, and fiberglass epoxy rods. Kevlar is most commonly used when individual fibers are placed within their own jackets. Steel and fiberglass members are frequently used in multifiber cables.

### Jacket

The jacket, like wire insulation, provides protection from the effects of abrasion, oil, ozone, acids, alkali, solvents, and so forth. The choice of the jacket material depends on the degree of resistance required for different influences and on cost.

A comparison of the relative properties of various popular jacket materials is provided in section 3, Table D.

### ADDITIONAL CABLE CHARACTERISTICS

Cables come reeled in various lengths, typically 1 or 2 km, although lengths of 5 or 6 km are available for single-mode fibers. Long lengths are desirable for long-distance applications since cables must be spliced end-to-end over the length of the run, hence the longer the cable, the fewer the splices that will be required.

Fiber coatings or buffer tubes or both are often coded to make identification of each fiber easier. In the long-distance link it's necessary to be able to ensure that fiber A in the first cable is spliced to fiber A in the second cable, and fiber B to fiber B, and so on.

In addition to knowing the maximum tensile loads that can be applied to a cable, it's necessary to know the installation load. This is the short-term load that the fiber can withstand during the actual process of installation. This figure includes the additional load that is exerted by pulling the fiber through ducts or conduits, around corners, etc. The maximum specified installation load will establish the limits on the length of the cable that can be installed at one time, given the particular application.

The second load specified is the operating load. During its installed life, the cable cannot withstand loads as heavy as it withstood during installation. The specified operating load is therefore less than the installation load. The operating load is also called the static load. For the purposes of this discussion we have divided the discussion on cables by *indoor* or *outdoor*.

Figure 2-13—Indoor Cables

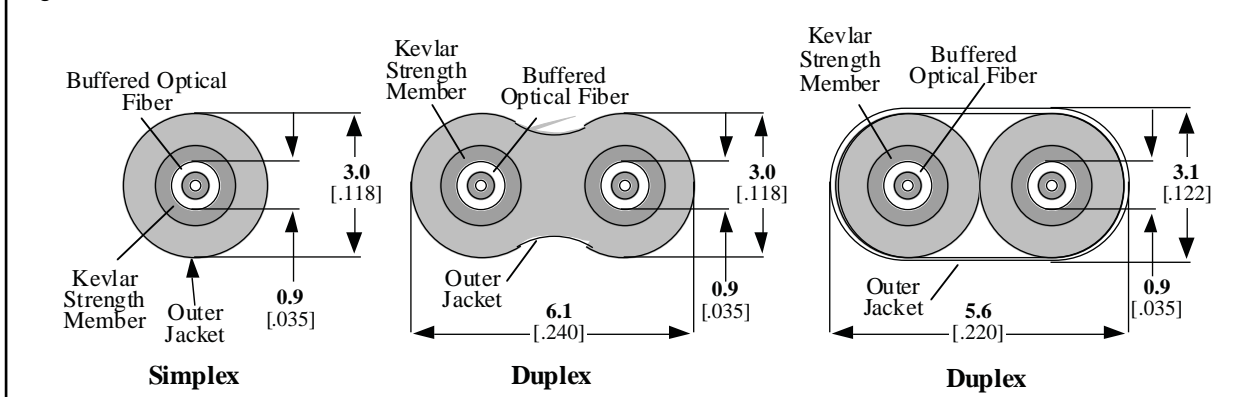

## SECTION 2—FIBER-OPTIC BASICS

### Indoor Cable

Cables for indoor applications (see Figure 2-13 below) include:

- Simplex
- Duplex
- Multifiber
- Undercarpet
- Heavy- and light-duty
- Plenum

*Simplex* is a term used to indicate a single fiber. *Duplex* refers to two optical fibers. One fiber may carry the signals in one direction; the other fiber may carry the signals in the opposite direction. (Duplex operation is possible with two simplex cables.)

Physically, duplex cables resemble two simplex cables whose jackets have been bonded together, similar to the jacket of common lamp cords. This type of cable is used instead of two simplex cables for aesthetic reasons and for convenience. It's easier to handle, there's less chance of the two channels becoming confused, and the appearance is more pleasing.

*Multifiber* cable, as the name would imply, contain more than two fibers. They allow signals to be distributed throughout a building. Multifiber cables often contain several loose-buffer tubes, each containing one or more fibers. The use of several tubes allows identification of fibers by tube, since both tubes and fibers can be color coded.

*Undercarpet* cable, as this name implies, is run across a floor under carpeting. It is frequently found in open-space office or work areas that are defined by movable walls, partitions. A key feature of this cable is its ability to be rearranged or

reconfigured as space needs change. One problem, however, is making turns without stressing the fibers. Unfortunately, the fiber on the outside of the turn must always take a longer path than the fiber on the inside. This unequal path length places differing stresses on the fibers. (Refer to Figure 2-14 below.)

*Heavy- and light-duty* cables refer to the ruggedness of the cable, one being able to withstand rougher handling than the other, especially during installation.

A *plenum* is the return or air-handling space located between a roof and a dropped ceiling. The National Electrical Code (NEC) has designated strict requirements for cables used in these areas.

Because certain jacket materials give off noxious fumes when burned, the NEC states that cables run in plenum must either be enclosed in fireproof conduits or be insulated and jacketed with low-smoke and fire-retardant materials.

Thus plenum cables are those whose materials allow them to be used without conduit. Because no conduit is used for these cables, they are easier to route. So, while plenum cables initially are more expensive, there are savings inherent in installation.

Other benefits are reduced weights on ceilings or fixtures and easier reconfigurations and flexibility for local area networks and computer data systems.

### Outdoor Cable

Cables for outdoor applications include:

- Aerial or overhead (as found strung between buildings or telephone poles).
- Direct burial cables that are placed directly in

Figure 2-14—Undercarpet Cable

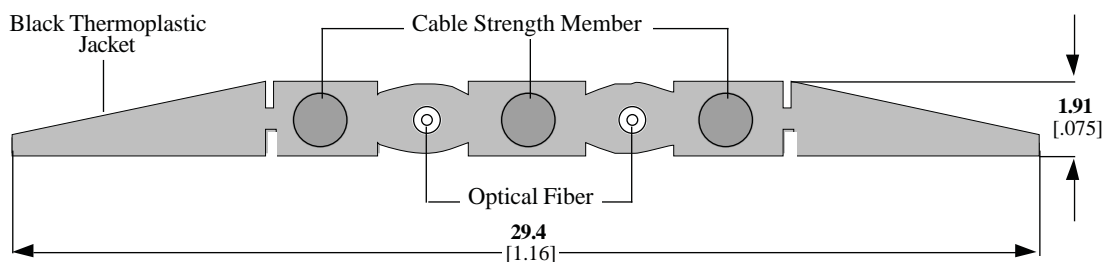

## SECTION 2—FIBER-OPTIC BASICS

a trench dug in the ground and then covered.

- Indirect burial, similar to direct burial, but the cable is inside a duct or conduit.
- Submarine cable is underwater, including transoceanic application.

All of the foregoing cables must be rugged and durable since their applications subject them to a variety of extremes. Typically, the internal glass fiber is the same for all types of fiber cable with some small exceptions.

Cables designed for underground use may contain one or more fibers encased in metal jackets and flooded with a moisture-proofing gel.

Section 3, Table E, offers a chart of questions that should be addressed when selecting cables for various requirements.

### Hybrid Cable

This is a unique type of cable generally available on special order only. It is designed for multipurpose applications where both optical fiber and twisted pair wires are jacketed together in those situations where both technologies are called for. This style cable is also useful when future expansion plans call for optical fiber.

Hybrid cable (Figure 2-15) allows for existing copper networks to be upgraded to fiber without the requirement for new cable. With hybrid cable, this can be accomplished without disrupting the existing service.

This cable style is also useful in applications such as local area networks (LANs) and integrated digital services networks (ISDNs) where easy or

smooth transition from copper to fiber is possible at a future time, basically because the hybrid cable permits the end user to be “fiber ready.”

Cable designs are available with multiple elements including the specific wire or fiber types (single- or multimode). Fibers are color coded for ready identification. As with conventional cable, hybrids can be manufactured to specific requirements.

### Breakout Cable

A breakout cable is one which offers a rugged cable design for shorter network designs. This may include LANs, data communications, video systems, and process control environments.

Figure 2-15—Hybrid Cable

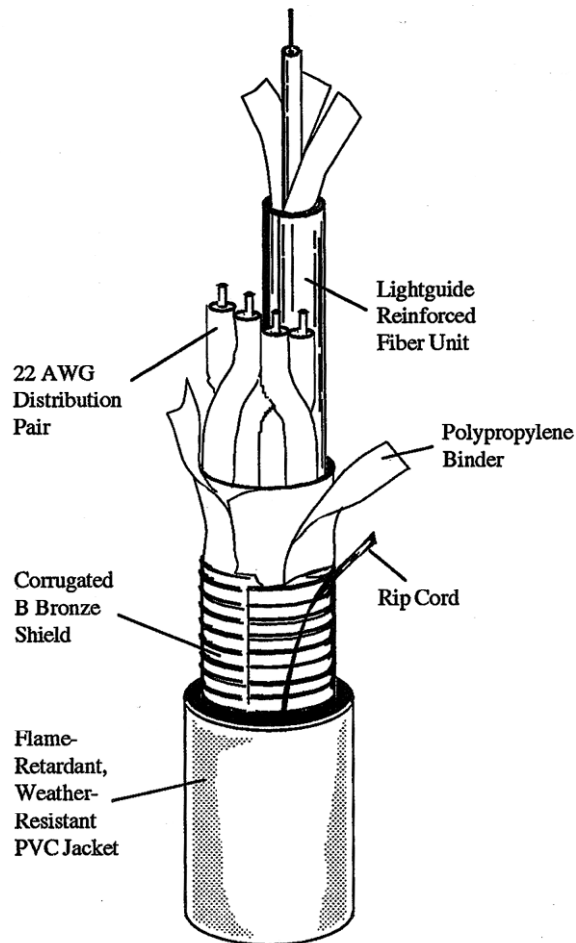

A tight buffer design is used along with individual strength members for each fiber. This permits direct termination to the cable without using breakout kits or splice panels. Due to the increased strength of Kevlar members, cables are usually heavier and physically larger than the telecom types with equal fiber counts.

The term breakout defines the key purpose of the cable. That is, one can “break out” several fibers at any location, routing other fibers elsewhere. For this reason breakout cables are, or should be, coded for ease of identification.

Because this type of cable is found in many building environments where codes may

require plenum cables, most breakout cables meet the NEC's requirements. The cable is available in a variety of designs that will accommodate the topology requirements found in rugged environments. Fiber counts from simplex to 256 are available.

## SECTION 2—FIBER-OPTIC BASICS

---

### CABLE SELECTION

The design and materials used in the cable construction selected will depend upon the environment and operation of the user's application. The variables are numerous and they will all have to be carefully weighed.

Refer to section 3, Table E, for a check-off sheet which may be copied or adapted for use when setting out to determine precisely which cable is best suited for individual applications. This chart shows many, if not all, of the variables that will have to be considered throughout this process.

### SOURCES

At each end of a fiber-optic link is a device for converting energy from one form to another. At the source is an electro-optic transducer, which converts an electrical signal to an optical signal. At the other end is the optoelectronic transducer which converts optical energy to electrical energy. This is discussed further on the next page under Detectors.

### SEMICONDUCTOR PN JUNCTION

The semiconductor pn junction is the basic structure used in the electro-optic devices for fiber optics. Lasers, LEDs, and photodiodes all use the pn junction, as do other semiconductor devices such as diodes and transistors.

### LASERS AND LEDs

Optical signals begin at the source with lasers or LEDs transmitting light at the exact wavelength at which the fiber will carry it most efficiently. The source must be switched on and off rapidly and accurately enough to properly transmit the signals.

Lasers are more powerful and operate at faster speeds than LEDs, and they can also transmit light farther with fewer errors.

LEDs, on the other hand, are less expensive, more reliable, and easier to use than lasers. Lasers are primarily used in long-distance, high-speed transmission systems, but LEDs are fast enough and powerful enough for short-distance communications, including video communications.

Lasers and LEDs are both semiconductor devices that come in the form of tiny chips packaged in either TO-style cans that plug into printed circuit board or microlens packages, which focus the beam into the fiber.

LEDs used in fiber optics are made of materials that influence the wavelengths of light that are emitted. LEDs emitting in the window of 820 to 870 nm are usually gallium aluminum arsenide (GaAlAs).

"Window," in this usage, is a term referring to ranges of wavelengths matched to the properties of the optical fiber. Long wavelength devices for use at 1300 nm are made of gallium indium arsenide phosphate (GaInAsP), as well as other combinations of materials.

Lasers provide stimulated emission rather than the simplex spontaneous emission of LEDs. The main difference between a LED and a laser is that the laser has an optical cavity required for lasing. This cavity is formed by cleaving the opposite end of the chip to form highly parallel, reflective, mirror-like finishes.

Laser light has the following attributes:

- Nearly monochromatic: The light emitted has a narrow band of wavelengths. It is nearly monochromatic—that is, of a single wavelength. In contrast to the LED, laser light is not continuous across the band of its special width. Several distinct wavelengths are emitted on either side of the central wavelength.
- Coherent: The light wavelengths are in phase, rising and falling through the sine-wave cycle at the same time.
- Highly directional: The light is emitted in a highly direction pattern with little divergence. Divergence is the spreading of a light beam as it travels from its source.

### SOURCE CHARACTERISTICS

Refer to section 3, Table F, for a comparison of the main characteristics of interest for both LED and laser sources.

## SECTION 2—FIBER-OPTIC BASICS

### SPECTRAL WIDTH

Earlier, we discussed material dispersion and the fact that different wavelengths travel through a fiber at different velocities. The dispersion resulting from different velocities of different wavelengths limits bandwidth.

Lasers and LEDs do not emit a single wavelength; they emit a range of wavelengths. This range is known as the spectral width of the source. It is measured at 50 percent of the maximum amplitude of the peak wavelength.

### DETECTORS

The detector in the fiber-optic system converts the optical signal into an electrical signal compatible with conventional equipment and communications networks.

A good signal detector responds well to light at the peak intensity wavelength of the light source and fiber combination used (800-900 nanometers, 1,000-2,000 nanometers). It also operates with low interference, has high reliability, long operating life, and small size.

### PHOTODIODE BASICS

In moving from the conduction band to the valence band (the energy bands in semiconductor material), by recombining electron-hole pairs, an electron gives up energy. In a LED, this energy is an emitted photon of light with a wavelength determined by the band gap separating the two bands. Emission occurs when current from the external circuit passes through the LED. With a photodiode, the opposite phenomenon occurs: light falling on the diode creates current in the external circuit.

Absorbed photons excite electrons from the valence band to the conduction band, a process known as intrinsic absorption. The result is the creation of an electron-hole pair. These carriers, under the influence of the bias voltage applied to the diode, drift through the material and induce a current in the external circuit. For each electron-hole pair thus created, an electron is set flowing as current in the external circuit. Several types of semiconductor detectors can be used in fiber-optic systems — the *pn photodiode*, the *pin photodiode*, and the *avalanche photodiode*.

Figure 2-16—PN Photodiode

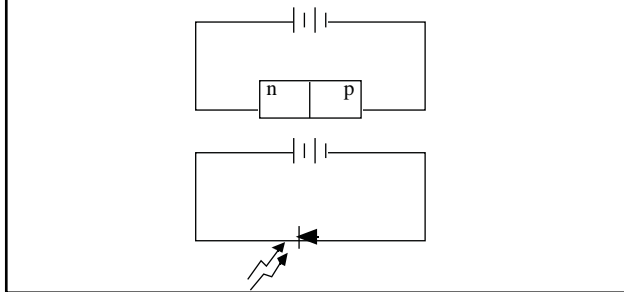

### The pn Photodiode

The simplest device is the *pn photodiode*. (Refer to Figure 2-16.) Two characteristics of this diode, however, make it unsuitable for most fiber-optic applications.

First, because the depletion area is a relatively small portion of the diode's total volume, many of the absorbed photons do not result in external current. The created hole and free electrons recombine before they cause external current. The received power must be fairly high to generate appreciable current.

Second, the slow tail response from slow diffusion makes the diode too slow for medium- and high-speed applications. This slow response limits operations to the kilohertz range.

Figure 2-17—PIN Photodiode

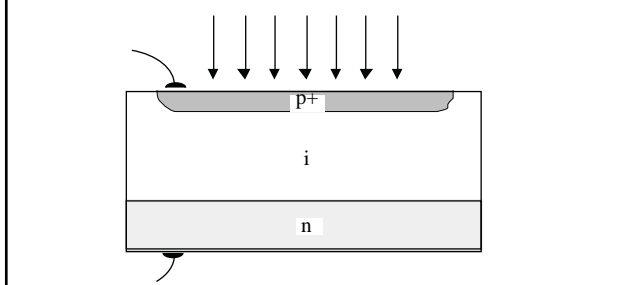

### The pin Photodiode

The *pin photodiode* is designed to overcome the deficiencies of its pn counterpart. While the pin diode works like the pn diode, it has its peak sensitivity to light signals at 1,000-2,000 nanometers in wavelength and can be used with LED sources and medium- to high-loss fiber.

The name of the pin diode comes from the layering of its materials: positive, intrinsic, negative—pin. (Refer to Figure 2-17.) Care must be exercised in

## SECTION 2—FIBER-OPTIC BASICS

---

selecting the supplier of this important element of the fiber-optic system. It should be understood that a tradeoff exists in arriving at the best pin photodiode structure and balancing the opposing requirements to achieve the best balance between efficiency and speed.

### Avalanche Photodiode

The *avalanche photodiode* (APD) is more complex, consisting of more layers of silicon material than the pin photodiode. The APD, which was developed specifically for fiber-optic applications, is efficient across a wider spectrum of light frequencies, suffers from less interference, and has a faster response time to signals than the pin photodiode. It is, however, more expensive as well.

### NOISE

Noise (any electrical or optical energy apart from the signal itself) is an ever-present phenomenon that seriously limits the detector's operation. If the signal is wanted energy, then noise is anything else—that is, unwanted energy.

Although noise can and does occur in every part of the system, it is of greatest concern in the receiver input because the receiver works with very weak signals that have been attenuated during transmission. An optical signal that is too weak cannot be distinguished from noise. To detect such a signal, either the noise level must be reduced or the power level of the signal must be increased.

An understanding of two types of noise, *shot noise* and *thermal noise*, are important to the understanding of fiber optics:

#### Shot Noise

Shot noise arises from the discrete nature of electrons. Current is not a continuous, homogeneous flow. It is the flow of individual discrete electrons.

Remember that a photodiode works because an absorbed photon creates an electron-hole pair that sets an external electron flowing as current. It is a three-step sequence: photo—electron-hole carriers—electron. The arrival and absorption of each photon and the creation of carriers are part of a random process. It is not a perfect homoge-

neous stream, rather it is a series of discrete occurrences. Therefore, the actual current fluctuates as more or less electron holes are created in any given moment. Shot noise occurs even without light falling on the detector.

#### Thermal Noise

Thermal noise, also called Johnson or Nyquist noise, arises from fluctuations in the load resistance of the detector.

Thermal and shot noise exist in the receiver independently of the arriving optical power. They result from the very structure of matter. They can be minimized by careful design of devices and circuits, but they cannot be eliminated. For this reason the signal must be appreciably larger than the noise in order to be detected.

As a general rule, the optical signal should be twice the noise current in order to be detected.

#### SIGNAL-TO-NOISE RATIO

The signal-to-noise ratio (SNR) is a common way of expressing the quality of signals in a system. SNR is simply the ratio of the average signal power to the average noise power from all noise sources.

#### BIT-ERROR RATE

For digital systems, bit-error rate (BER) usually replaces SNR as a measure of system quality. BER is the ratio of incorrectly transmitted bits to correctly transmitted bits. A ratio of  $10^{-9}$  means that one wrong bit is received for every one-billion bits transmitted.

#### DETECTOR CHARACTERISTICS

The characteristics of interest are those that relate most directly to use in a fiber-optic system. These characteristics are:

- Responsivity: The ratio of the diode's output current to input optical power. It is expressed in amperes/watt (A/W).
- Quantum Efficiency: The ratio of primary electron-hole pairs (created by incident photons) to

## SECTION 2—FIBER-OPTIC BASICS

the photons incident on the diode material). This deals with the fundamental efficiency of the diode for converting photons into free electrons.

- **Dark Current:** The thermally generated current in a diode; it is the lowest level of thermal noise.
- **Minimum Detectable Power:** The minimum power detectable by the detector determined the lowest level of incident optical power that the detector can handle.
- **Response Time:** The time required for the photodiode to respond to optical inputs and produce external current. Usually expressed as a rise time and a fall time, measured in tens of nanoseconds.

### TRANSMITTERS AND RECEIVERS

#### BASIC TRANSMITTER CONCEPTS

The transmitter contains a driver and a source. (Refer to Figure 2-18.) The input to the driver is the signal from the equipment being served. The output from the driver is the current required to operate the source.

Figure 2-18—Basic Transmitter Block Diagram

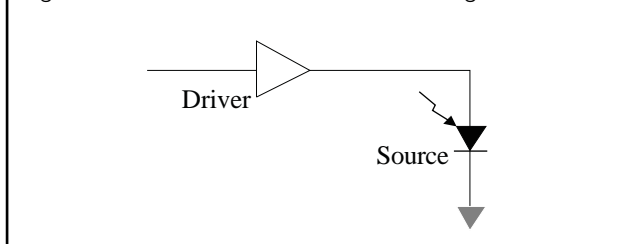

Most electronic systems operate on standard, well-defined signal levels. Television video signals use a 1 volt peak-to-peak level.

Digital systems use different standards, depending on the type of logic circuits used in the system. These logic circuits define the levels for the highs and lows that represent the 1s and 0s of digital data. Digital logic circuits, all further defined under the Glossary in section 3, are:

- Transistor-transistor logic (TTL) used in many applications.
- Emitter-coupled logic (ECL), faster than TTL and not able to be mixed with TTL, it is usually

found in high-speed systems.

- Complementary metal-oxide semiconductor (CMOS), which is rapidly becoming the replacement for TTL because of its very low power consumption.

The drive circuits of the transmitter must accept signal input levels, then provide the output current to drive the source. Characteristics for specifying a transmitter (or a receiver) are basically the same as would apply for any electronic circuit. These include:

- Power supply voltages
- Storage and operating temperature ranges.
- Required input and output voltage levels (which indicate video, audio, TTL or ECL compatibility).
- Data rate/bandwidth.
- Operating wavelength.

#### BASIC RECEIVER CONCEPTS

The receiver contains the detector, amplifier, and output circuit. (Refer to Figure 2-19) The amplifier amplifies the attenuated signal from the detector.

Figure 2-19—Basic Receiver Block Diagram

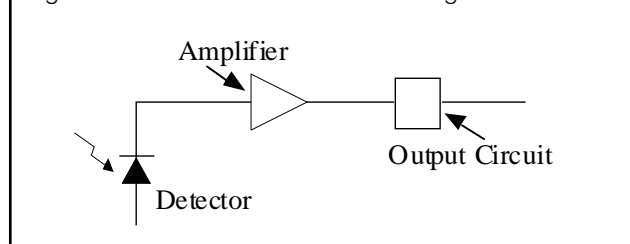

The output circuit can perform many functions, such as:

- Separation of the clock and data.
- Pulse reshaping and retiming.
- Level shifting to ensure compatibility—TTL, ECL, and so forth—with the external circuits.
- Gain control to maintain constant levels in response to variations in received optical power and variations in receiver operation from temperature or voltage changes.

Because the receiver deals with highly attenuated light signals, it can be considered the principal component around which the design or selection

## SECTION 2—FIBER-OPTIC BASICS

of a fiber-optic system revolves. It is in the photo-detector and first stage of amplification that the signal being transmitted is at its weakest and most distorted. It is reasonable to say that this is the central part of the link. Thus decisions affecting other parts of the link are made with the receiver in mind. Decisions about the modulation of the transmitter are decided, at least in part, by the requirements of the receiver.

Important receiver characteristics include:

- Power supply voltages
- Storage and operating temperature ranges.
- Required input and output voltage levels (which indicate TTL or ECL compatibility).
- Data rate/bandwidth.
- Sensitivity.
- Dynamic range.
- Operating wavelength.

*Sensitivity* specifies the weakest optical signal that can be received. The minimum signal that can be received depends on the noise floor of the receiver front end.

*Dynamic range* is the difference between the minimum and maximum acceptable power levels. The minimum level is set by the sensitivity and is limited by the detector. The maximum level is set by either the detector or the amplifier. Power levels above the maximum saturate the receiver or distort the signal. The received optical power must be maintained below this maximum.

### AMPLIFIERS

The two most common designs found in fiber-optic receivers are *low-impedance amplifier* and *transimpedance amplifier*. (See Figure 2-20.)

### DUTY CYCLE IN THE RECEIVER

The reason for concern for duty cycle in the modulation codes is that some receiver designs put restrictions on the duty cycle. A receiver distinguishes between high and low pulses by maintaining a reference threshold level. A signal level above the threshold is seen as a high or 1; a signal level below the threshold is seen as a low or 0. The shifting of threshold level would cause no problems

in an ideal, noiseless receiver. But receivers are neither perfect or noiseless. Signal levels not only vary somewhat, but the signals also contain noise.

There are two ways to get around such errors. The first is to maintain a duty cycle close to 50 percent. Manchester and biphas-M codes, by definition, always have a 50 percent duty cycle, so they satisfy the requirement. Their drawback is that they require a channel bandwidth of twice the data rate and they also increase the complexity of the transmitter somewhat.

The second method of avoiding bit errors is to design a receiver that maintains the threshold without drift. The reference threshold is always midway between high and low signal levels. One way to do this is by a dc-coupled receiver, which is designed to operate with arbitrary data streams. The receiver is edge-sensing, meaning that it is sensitive to changes in level and not to the levels themselves. This type of receiver reacts only to pulse transitions.

### TRANSCEIVERS AND REPEATERS

A transceiver is a transmitter and a receiver packaged together to permit both transmission and receipt of signals from either station.

A repeater is a receiver driving a transmitter. It's used to boost signals when the transmission distance is so great that the signal will be too highly attenuated before it reaches the receiver. The repeater accepts the signal, amplifies and reshapes it, and feeds the rebuilt signal to a transmitter.

Figure 2-20—Low- and Transimpedance Amplifiers

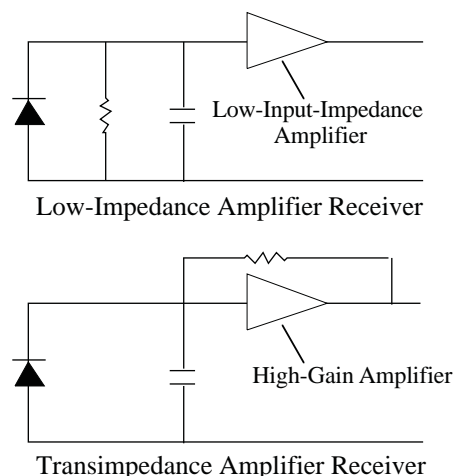

## SECTION 2—FIBER-OPTIC BASICS

### CONNECTORS AND SPLICES

The requirements for fiber-optic connection and wire connection are very different. In wiring, two copper conductors can be joined directly by solder or by connectors that have been crimped or soldered to the wires. The purpose is to create contact between the mated conductors to maintain a path across the junction.

In fiber-optics, the key to interconnection is precise alignment of the mated fiber cores (or spots in the case of a single-mode fibers) so that nearly all of the light is coupled from one fiber into the other fiber. Precise and careful alignment is vital to the success of system operation.

### CONNECTOR REQUIREMENTS

Connectors provide the mechanical means for terminating optical fibers to other fibers and to active devices, thereby connecting transmitters, receivers, and cables into working links.

The primary task of the fiber optic connector is to minimize the optical loss across the interface of the coupled fiber. This loss is expressed in decibels (dB). High-performance connectors are classified as those with less than 1 dB of loss; medium performance is less than 2 dB. Losses occur from inexact mating of the fibers, and the surface condition of the fiber ends. (See Figure 2-21.)

The second task of the connector is to provide mechanical and environmental protection and stability to the mated junction. Lastly, the connector design should permit rapid and uncomplicated termination of a cable in a field setting.

An ideal connector would encompass:

- A fiber-alignment scheme yielding low loss.
- Physically small.
- Rugged construction.
- Easily field terminated.
- Field repairable.
- Good thermal characteristics.
- Offer excellent fiber/cable strain relief.
- Accessory tooling to prepare fiber and cable.
- Factory terminated cable assemblies which enable users to field connectorize or splice assemblies using fusion or mechanical splices.
- Be of moderate cost.

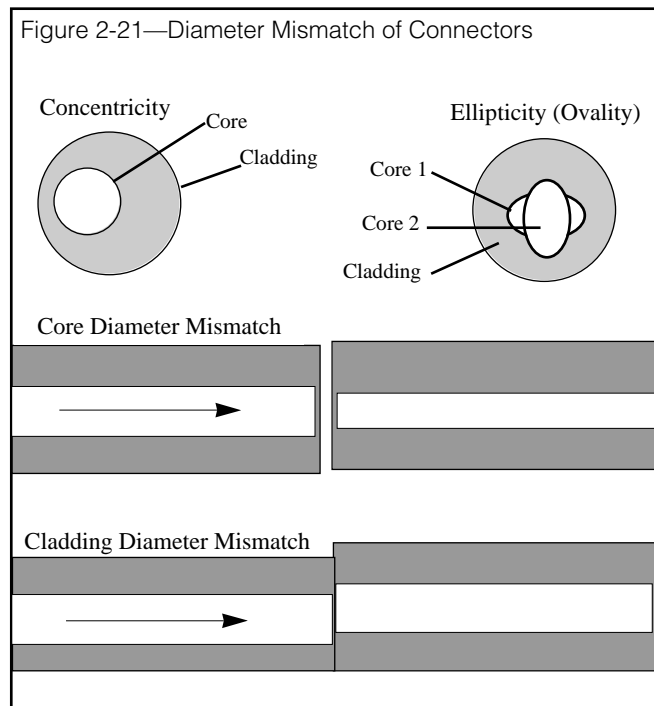

### CAUSES OF LOSS IN AN INTERCONNECTION

Losses in fiber-optic interconnections are caused by three factors: (1) Intrinsic, or fiber-related factors caused by variations in the fiber itself.; (2) extrinsic, or connector-related factors contributed by the connector itself; or (3) system factors contributed by the system itself.

In joining two fibers together it would be nice to safely assume that the two are identical. However, the fact is that they usually are not. The fiber manufacturing process allows fibers to be made only within certain tolerances.

Under section 3, Table G, Intrinsic Loss Factors, lists the most important variations in tolerances that cause intrinsic loss, i.e., core diameter, cladding diameter, numerical aperture mismatch, concentricity, ellipticity (or ovality) of core or cladding.

Connectors and splices contribute extrinsic loss to the joint. The loss results from the difficulties inherent in manufacturing a connecting device to the exacting tolerances that are required. The four main causes of loss that a connector or splice must control are:

- Lateral displacement: A connector should align the fibers on their center axes. When one fiber's axis does not coincide with that of the other, loss occurs.

## SECTION 2—FIBER-OPTIC BASICS

---

- End separation: Two fibers separated by a small gap will suffer loss.
- Angular misalignment
- Surface roughness.

Again, see Figure 2-21 on the previous page. When two fibers are not perfectly aligned on their center axes, lateral displacement loss occurs even if there is no intrinsic variation in the fiber.

First, the fiber ends must be optically square and smooth, and second the end-to-end presentation of both fibers must align and the gap (air space) be made minimal. In the case of single-mode connectors, the fiber ends may come into contact to reduce the reflective losses.

Two fibers separated by a small gap experience end-separation loss of two types. First is a Fresnel reflection loss caused by the difference in refractive indices of the two fibers and the intervening gap, which is usually air. The second type of loss for multimode fibers results from the failure of high-order modes to cross the gap and enter the core of the second fiber.

Either of these conditions will contribute to loss, the result being dependent on the numerical aperture (NA) of the fiber.

A gap between a transmitting and a receiving fiber will also introduce loss because the air between the fibers is of a different refractive index than the core of the fibers. With air between the fibers, the Fresnel loss would be 0.4 dB. This can be reduced by immersing the junction in a fluid of “matching liquid,” typically with a refraction index the same as that of the core. Some connectors use this feature, but at the risk of fluid depletion and possible introduction of contaminants.

The ends of mated fibers should be perpendicular to the fiber axes and perpendicular to each other. In order to ensure this, fiber ends are made square and smooth by one of two methods. These are the lap-and-polish (grind) method and the scribe-and-break (cleave) method. The lap-and-grind method involves the use of a positioning fixture and grinding/lapping compounds.

Once the ends are square and smooth, the connector design must address alignment parameters to ensure

lowest loss. In particular, the connectors must minimize fiber lateral offset and angular misalignment. Finally, the fiber face must be smooth and free of defects such as hackles, burrs, and fractures. Irregularities from a rough surface disrupt the geometrical patterns of light rays and deflect them so they will not enter the second fiber, thus causing surface finish loss.

System-related factors can also contribute to loss at a fiber-to-fiber joint. Refer to page 2-6, where the subject of dispersion is discussed, and specifically describes how modal conditions in a fiber change with length until the fiber reaches equilibrium mode distribution (EMD).

Initially, a fiber may be over filled or fully filled with light being carried both in the cladding and in high-order modes. Over distance, these modes will be stripped away. At EMD, a graded-index fiber has a reduced NA and a reduced active area of the core carrying the light.

Consider a connection close to the source. The fiber on the transmitting side of the connection may be over filled. Much of the light in the cladding and high-order modes will not enter the second fiber, although it was present at the junction. This same light, however, would not have been present in the fiber at EMD, so it would also not have been lost at the interconnection point.

Next consider the receiving side of the fiber. Some of the light will spill over the junction into cladding and high-order modes. If the power from a short length of fiber were to be measured, these modes would still be present. But these modes will be lost over distance, so their presence is misleading.

Similar effects will be seen if the connection point is far from the source where the fiber has reached EMD. Since the active area of a graded-index fiber has been reduced, lateral misalignment will not affect loss as much, particularly if the receiving fiber is short. Again, light will couple into cladding and high-order modes. These modes will be lost in a long receiving fiber.

Thus, the performance of a connector depends on modal conditions and the connector’s position in the system. In evaluating a fiber-optic connector or splice, we must know conditions on both the launch (transmitter) side and the receive (receiver) side of the connection.

## SECTION 2—FIBER-OPTIC BASICS

---

Four different conditions exist:

- Short launch, short receive.
- Short launch, long receive.
- Long launch, short receive.
- Long launch, long receive.

### LOSS IN SINGLE-MODE FIBERS

It is important to note that connectors and splices for single-mode fibers must also provide a high degree of alignment. In many cases, the percentage of misalignment permitted for a single-mode connection is greater than for its multimode counterpart. Because of the small size of the fiber core, however, the actual dimensional tolerances for the connector or splice remain as tight or tighter.

### ALIGNMENT MECHANISMS AND SPLICE EXAMPLES

Many different mechanisms have been used to achieve the high degree of alignment that is required in a connector or splice. Splicing is the name of the process whereby two fibers or cables are joined together. Fiber splicing consists of: preparation of the fiber; cleaving the fiber; inspection of the cleave; placing of the fibers in an alignment fixture; alignment or tuning of fibers; bond splice; inspection and testing; and enclosing of the splice for protection.

Basically, there are two types of splices: *fusion* and *mechanical*.

### FUSION SPLICES

The fusion splice is accomplished by applying localized heating at the interface between two butted, prealigned fiber ends, causing the fibers to soften and fuse together to form a continuous glass strand. This system offers the lowest light loss and the highest reliability. Loss should be at .5 dB/splice or less.

Specifically, the fusion splice consists of:

- Joining glass fibers by melting them together using an electric arc.
- Precision controlled for fiber uniformity.
- Permanent, highly reliable, low in cost.
- Average of 50 splices can be done per day in one location by a single team of two persons.
- Typically 0.1 to 0.3 dB loss per splice.

A fusion-splice joint can maintain a breaking strain of more than one percent. This means that such splices can be used when manufacturing fiber-optic cable if long, continuous cables of tens of kilometers are required.

The down side of this method is that training is required before using the expensive equipment that effects the fusion splice. Depending on the complexity of the installation, this may not be the first choice.

The fusion-splice process employed can vary depending on the type of splicer used. The two most common types are the *local injection detection (LID) splicer* and the *manual splicer*. Both splicers use electrodes to melt the fiber ends together.

### The LID Splicer

The *LID splicer* or automatic splicer, is a process that employs microbending techniques to launch light into the fiber before the fiber end. On the opposite fiber to be spliced a microbend is again used, but this time with a detector to remove the launched light. This allows the processor in the splicer to align the fiber to where the greatest optical power level is achieved.

The process for this splicing is positioning the fiber in clamps and alignment fixtures. By activating the automatic alignment function, the splicer runs through various X, Y, and Z alignments for optimizing the transmission through the two fiber ends. When this is accomplished, the splicer indicates maximum alignments and the splicer operator then fuses the fibers by activating electrodes.

## SECTION 2—FIBER-OPTIC BASICS

### The Manual Splicer

A *manual splicer* usually has two alignment fixtures, each located on one side of the splicer permitting manual aligning of fiber end through X, Y, and Z axes.

The splicer having prepared each fiber for splicing then places the fibers in clamps located on each side of the electrodes. The clamp and alignment fixtures are then manually manipulated while the splicer views the process through a microscope. In this process the splicer can inspect the fiber ends and the alignment process.

The manual fusion splicer is less expensive than the local injection detection splicer and is good for making multimode splices. Because this unit aligns the fibers on the outer diameter of the fibers, losses can be slightly higher than a LID set which optimizes the fiber cores.

It should be noted that because all fibers are not identical, a good fusion splicer should be easily adjustable to change arc duration and current to the electrodes. The reason is that different fibers can melt or fuse at different temperatures and require longer or slower fusion arcs.

Further, when using LID systems, the technique allows for optimum core alignment. However, the measurements obtained from this technique may not match the OTDR measurements which would be optimized using the same wavelength that the system would operate at.

### MECHANICAL SPLICE

Mechanical splices are the most straightforward. The installer merely terminates the two ends of the cable that are to be joined and then connects them with an inexpensive barrel splice.

This method is fine for short-haul systems, but introduces light loss of up to 4 dB/splice that may degrade a system that operates over a distance greater than two kilometers. It consists of:

- Fibers joined by a glass capillary.
- Splice is permanent, with good reliability and low loss.
- Average of 50 splices per day in one location.
- Typically 0.1 to 1dB loss per splice (at 850 or 1300 nm).
- Can be reusable.

Mechanical splicing methods include *rotary*, *central glass alignment guide (or four-rod)*, and *elastomeric*.

### The Rotary Splice

The *rotary splice* (see Figure 2-22 ) is a newer method of splicing optical fibers. The rotary is both a connector and a splice as it does have the capability to be mated and unmated like connectors, yet has the low attenuation features of an optical splice. Like optical connectors, this splice takes longer to terminate, requires more components, and has a higher component failure rate prior to testing.

### Central Glass Alignment Guide Splice

The *central glass alignment guide splice* uses four precision glass rods to precisely align optical fibers. The rods are fused together creating an inner hollow core. At each end of the splice, the rods are bent at a slight angle allowing the fibers to orient themselves in the uppermost V groove of the rods. By positioning the fiber where the ends will be in the middle of the splice, the fibers can be precisely rotated to allow for the lowest attenuation.

Figure 2-22—Rotary Splice

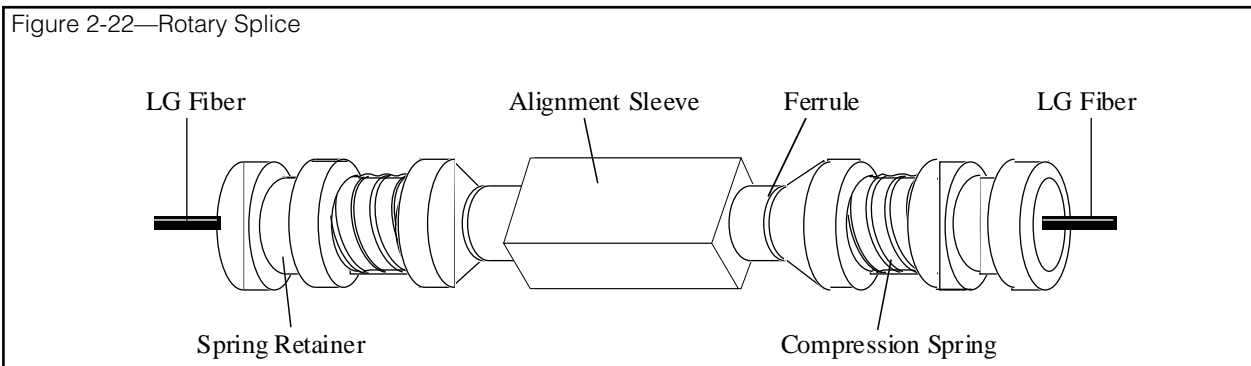

## SECTION 2—FIBER-OPTIC BASICS

With the use of splice holders, this type of splice can be used for temporary splices in both lab and field applications. By using a splice holder, the splice is easier to work with and has a substantially lower discard rate due to its alignment rod technique.

For permanent installations, the hollow section with the rods is filled with UV fluid. After aligning the scribed fibers, the splice is cured in minutes by using a UV lamp. Like all good splices, the process requires a good end face to maintain low attenuation. The advantage of this type of splice are versatility for field and lab applications and low tooling costs.

### Elastomeric Splice

The *elastomeric* splice (Figure 2-23) is made from a plastic (elastic) material formed into a mold. The mold allows for a hole to be made. The elastomeric material is flexible enough so the fibers can be positioned and firm enough so the fibers are retained during handling and splicing without the need for positioning equipment.

Because the fibers are mated into the same mold, alignment can be maintained with low attenuation. The fibers can be tuned for low attenuation if care is taken in removing the fibers prior to tuning. Like the central glass alignment method, the elastomeric

method uses matching fluids or UV fluids depending on the application. The need for a good scribed optical fiber will allow for low attenuation measurements. A typical elastomeric splice will introduce light loss of less than 1 dB/splice.

### FIBER PREPARATION

Proper preparation of the fiber end face is critical to any fiber-optic connection. The two main features to be checked for proper preparation are perpendicularity and end finish.

The end face ideally should be perfectly square to the fiber and practically should be within one or two degrees of perpendicular. Any divergence beyond two degrees increases loss unacceptably. The fiber face should have a smooth, mirrorlike finish free from blemishes, hackles, burrs, and other defects.

The two most common methods used to produce correct end finishes are the *cleaving* (or scribe-and-break) method and the *polish* method. The first is used with splices and the second is more commonly used with connectors.

Whichever method is used, it is necessary to prepare a fiber for splicing. To do this the protective jackets and buffers must be removed to allow access to the optical fiber. The outer and the inner jackets are

Figure 23—Elastomeric Splice

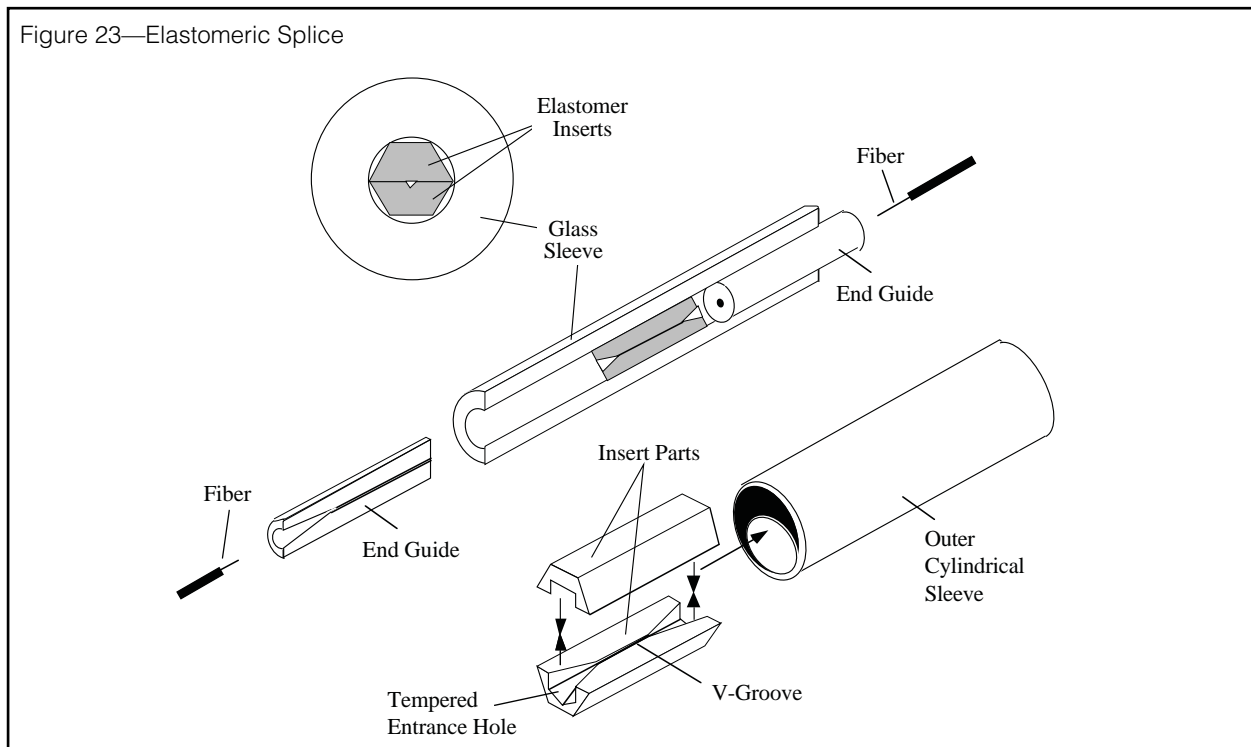

## SECTION 2—FIBER-OPTIC BASICS

removed, exposing the Kevlar strength member, the buffer tube, and the fiber. The fiber still has the protective coatings which will also have to be removed.

Standard cable strippers can be used to remove the outer jacketing. The amount of Kevlar removed can vary depending upon the design of the strength member of the cable. If the cable does not incorporate a strength member, the Kevlar can be used as such.

The buffer tubes, like the outer jackets, can be removed by mechanical stripping tools with the operator taking care not to kink or damage the internal coated fibers.

Once the coated fiber is exposed, the splicer must remove the protective coatings to start the actual fiber splicing. Most coated fibers can be stripped using mechanical or chemical methods. The splicer should also take care to use tools or procedures that will not damage the fibers.

After the coating is removed, the splicer should clean the fiber with Isopropyl alcohol to assure that the fiber is clean. Contaminants on fiber can cause the fiber to misalign itself in the alignment fixture.

types of splicing that will be done. When selecting this tool, keep the following factors in mind:

- **Fiber accuracy:** The more accurate the tool for maintaining a low angle tolerance, the lower the loss will be in the splice.
- **Costs:** The costs should be in line with the job to be performed. Don't spend a thousand dollars on a tool if you're going to use it in a polish-and-grind optical connector. A major cost of the tool is the type of blade supplied. Diamond carbide and sapphire blades are the most common, with diamonds rating higher over sapphire.
- **Maintenance:** Can the tool be calibrated easily? If not, you may need a second tool if your first one must be sent to the factory for calibration and/or if the blade must be replaced.
- **Amount of fiber exposed:** A key factor to remember is how much fiber must be exposed during the cleave process. The more fiber, the more difficult the stripping process becomes. A tool which requires only a small amount of exposed fiber and which can be adjusted for longer lengths is an ideal tool.

Figure 2-24—Cleaving the Fiber

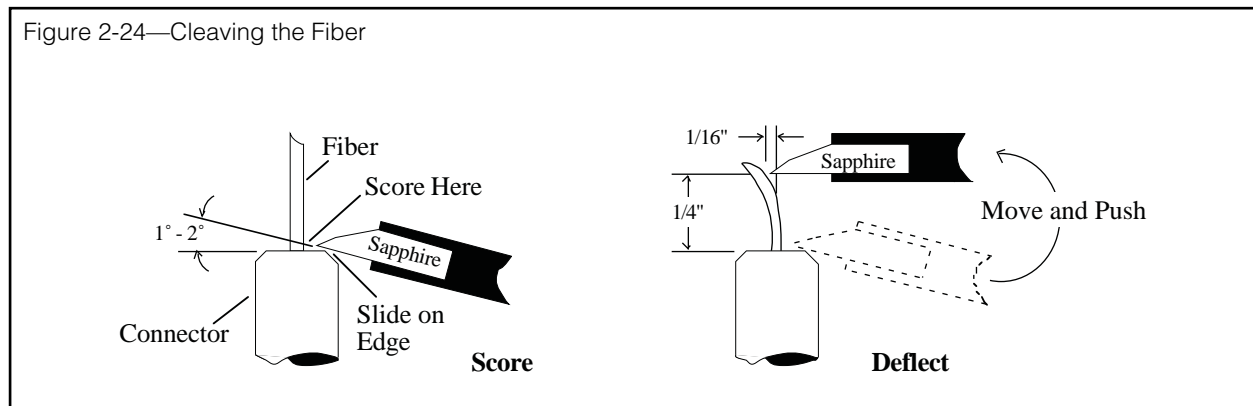

### Cleaving

This is a process which allows the operator to break or scribe the fiber with a 90 degree end face perpendicular to the axis of the fiber with little surface damage or irregularities to the fiber. (See Figure 2-24.)

There are several types of cleavers available for use in lab or field environments. These vary in price and performance and should be chosen for the

### Cleaving Methods

Optical fiber is typically cleaved in one of four ways:

- Placing the fiber across a curved surface (again refer to Figure 24) and bringing the blade down to the fiber. The blade is to scratch the fiber, not cut through it. Slight pressure on manual tools may have to be applied. Tools designed for the fibers size will automatically apply the proper tension. Once the scratch is made, the fiber will

## SECTION 2—FIBER-OPTIC BASICS

break due to the curvature of the fiber.

- Placing the fiber in a horizontal fixture where the blade will scratch the fiber and the tension is applied from the end of the fiber pulling the fiber from the scribed location.
- Using a tool which scribes the entire circumference of the fiber, and then pulling from the ends of the fiber.
- Using a hand scribe or pen scribe where the fiber is placed in the hand or fixture and the operator draws the scribe tool across the fiber. After the scribe, the operator breaks the fiber off by tugging with his hand.

Even with the best tools and operator experience, the cleave, scribe, or break can be inadequate. Because of this, the end of the cleaved fiber should always be inspected carefully with a field microscope.

Upon inspection, the splicer should look for nice perpendicular end face to the axis of the fiber. No “lips” where the fiber edge is exposed or “hackle” where the fiber has broken away from the fiber. The fiber should have a good clean end face free of cracks, chips, and scratches. The angle of the fiber should not be visible. If any of these conditions can be seen, the cleaving cycle should be repeated.

### Polishing

Polishing is done in two or more steps with increasingly finer polishing grits. Wet polishing is recommended, preferably using water, which not only lubricates and cools the fiber, but also flushes polish remnants away. The connector and fiber face should be cleaned before switching to a finer polishing material.

Polishing has a second function: It grinds the connector tip to a precise dimension. This dimension controls the depth that the connector tip and fiber extend into the bushing that holds the two connectors. It thereby controls the gap between mated fibers. If the tip dimension is too long, the mated fibers may be damaged when they are brought together. If the dimension is too short, the gap may be large enough to produce unacceptable losses.

The first polishing steps grind the connector tip and fiber to the correct dimension. The final step

Figure 2-25— Connector Types

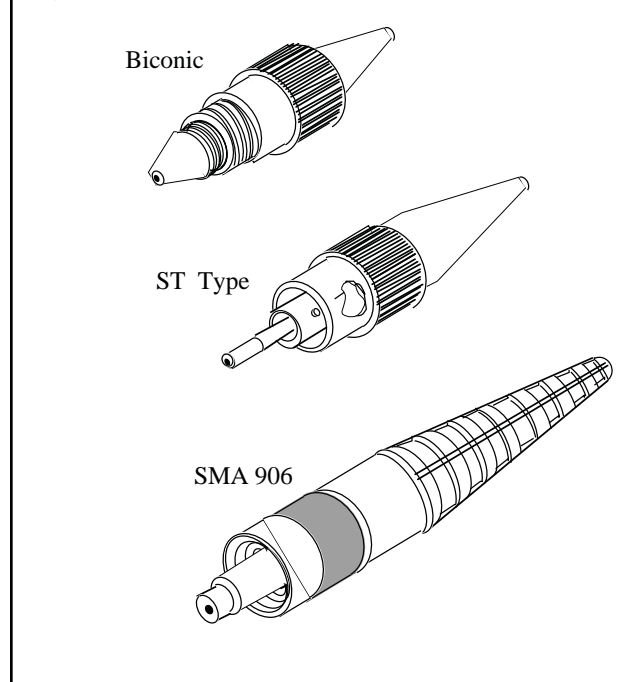

polishes the fiber face to a mirrorlike finish.

As with cleaved fiber, polished fiber should be inspected under a microscope. Small scratches on the fiber face are usually acceptable, as are small pits on the outside rim of the cladding. Large scratches, pits in the core region, and fractures are unacceptable.

Some poor finishes, such as scratches, can be remedied with additional polishing. Fractures and pits, however, usually mean a new connector must be installed.

### CONNECTOR ASSEMBLY

Ideally one connector type will be used throughout your system or network for ease of testing, maintenance, and administration. The most common connectors found are biconic, ST type and SMA. See Figure 2-25 showing these connector types.

#### Biconic Connectors

Available in both single- and multimode versions, the biconic is a small size connector with screw thread, cap, and spring-loaded latching mechanism. Its advantages are low insertion and return loss and that it is very common with manufacturers and telephone companies. Its disadvantages are

## SECTION 2—FIBER-OPTIC BASICS

poor repeatability and no “keying.” Typically, these connectors are not only expensive, they are not field installable.

### ST Type Connectors.

The ST uses a keyed bayonet style coupling mechanism versus the more common threaded styles found in other connector types. The bayonet feature allows the user to mechanically couple the connector with a push-and-turn motion. This prevents installers from over-tightening threads and damaging the connectors and/or fiber.

The ST, originally manufactured by AT&T, has a very low profile and is suitable for small areas. It is available in single- and multimode versions each having losses of only 1 dB/rated pair.

### SMA Connectors

The SMA is a small size connector with SMA coupling nut dry connection. It is available in multimode versions only and has become the de facto standard in multimode applications.

Its advantages are its relatively low cost and ready availability because there are many suppliers. Disadvantages are that not all SMA connectors intermate and performance loss tends to be between 1—4 dB for splice applications.

The SMA is available in two major styles: the 905 and the 906. The 905 is a higher loss, lower quality connector. The 906 (used only in splices) has a step-down ferrule and uses an alignment sleeve to improve performance.

For the purposes of this publications, we have provided assembly instructions on the SMA connector because it is not only one of the most common connectors found in fiber-optic systems, but it also typifies the process.

### SMA Connector Assembly Instructions

- Slide the strain relief boot and crimp sleeve onto the cable. (Hint: For ease in assembly, tape strain relief boot out of the way.)
- Strip cable per manufacturer’s instructions to recommended dimensions. (See Figure 2-26.)

- Soak the exposed fiber in acetone for 30 seconds. Wipe dry with soft paper tissue.
- At this point it is recommended that the connector be slid onto the cable to assure a proper fit. Once this has been ascertained, remove the connector and proceed with the next step.
- Screw the connector into the installation tool for ease of handling.
- Mix the epoxy. Fold back the cable’s Kevlar strains and dip the bare fiber into the epoxy to coat its surface.
- Thread the fiber through the connector until the outer jacket butts up against the connector backpost. Do not force the fiber.

(NOTE: Wicking of epoxy is recommended. This is accomplished by sliding the fiber in and out gently several times without completely removing the fiber from the connector.)

- While holding the connector with the installation tool, slide the crimp sleeve over the Kevlar onto the knurled portion of the backpost until it butts. (See Figure 2-27.)

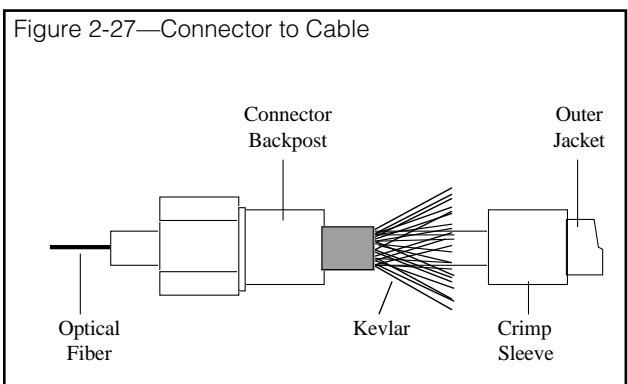
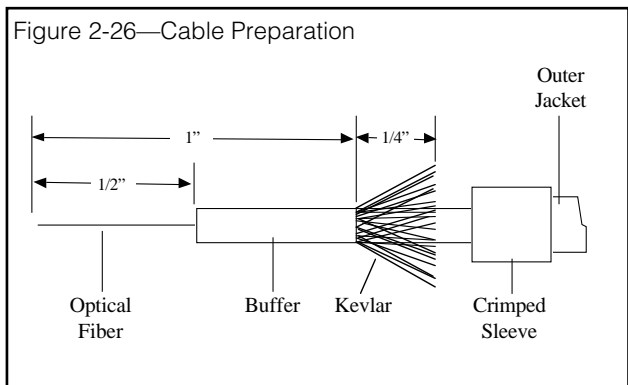

## SECTION 2—FIBER-OPTIC BASICS

- Crimp the sleeve using a crimping tool. (See Figure 2-28.)
- Remove the installation tool and apply a bead of epoxy to the front tip of the connector

(NOTE: Take care that epoxy does not get on the barrel of the connector. If this does occur, clean the connector with Isopropyl alcohol after the epoxy sets and prior to polishing.)

- Cure the epoxy for approximately 5-10 minutes.
  - Using a scribing tool, score the fiber close to the epoxy bead and gently pull the fiber until it separates.
  - Place lapping film with 15, 3, and 1 micron aluminum oxide grits on a smooth surface, preferably glass.
- (HINT: Leave a portion of the film overhanging the glass for easy removal.)
- Gently rub the fiber on dry 15 micron film in a circular motion until the fiber is flush with the bead of epoxy.
  - Install the connector in the polishing tool.
  - Coarse polishing is performed on the 12 micron film by moving the polishing tool in a gentle figure-8 motion while lubricating the film with water. Progress polishing options to a figure eight pattern and continue for approximately one minute or until all epoxy is removed.

- Continue the process on the 3 micron film approximately 25-30 figure eight polishing patterns on the 1 micron film should produce a mirror-like finish. A 5 micron film is recommended for an optimum finish.

(NOTE: In order to maintain proper end separation, the connector must be polished so that it is flush with the tool. A quick check is to place the polishing tool with the connector on a flat piece of glass. If any rocking action is present, more polishing is needed. Return to 1 micron film for additional polishing.)

- Cleaning—Remove the connector from the polishing tool and rinse both items with water to remove any fine grit particles.

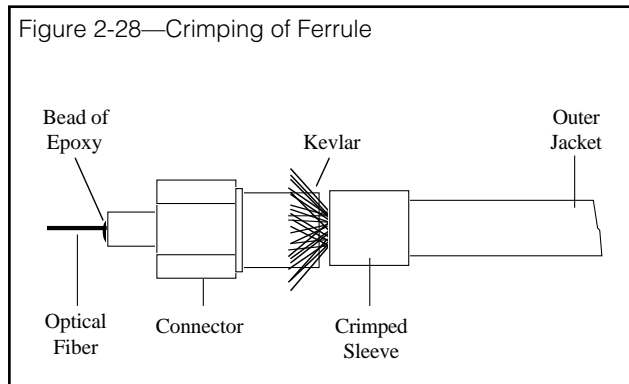

- Trim the Kevlar close to the crimp sleeve. Then place the strain relief boot over the crimp sleeve.
- Inspection—Until experience is gained, the polished fiber should be inspected under a 50X or greater magnification.
- The fiber should possess a mirror-like finish and be flush with the face of the connector. The fiber should be free from most pits, cracks, and scratches.
- Connector should also be cleaned with alcohol or a lens cleaner.

## COUPLERS AND NETWORKS

A *coupler* is a device that will divide light from one fiber into several fibers or, conversely, will couple light from several fibers in to one.

Important application areas for couplers are in networks, especially local area networks (LANs), and in wavelength-division multiplexing (WDM).

*Networks* are composed of a transmission medium that connects several nodes or stations. Each node is a point at which electronic equipment is connected onto the network. The network includes a complex arrangement of software and hardware that ensures compatibility not only of signals but also of information.

Most important in a network is its logical topology. The logical topology defines the physical and logical arrangement. The most common logical topologies are point-to-point, star, ring, or bus structure. Refer to Figure 2-29 on the next page.

## SECTION 2—FIBER-OPTIC BASICS

Figure 2-29—Network Topologies

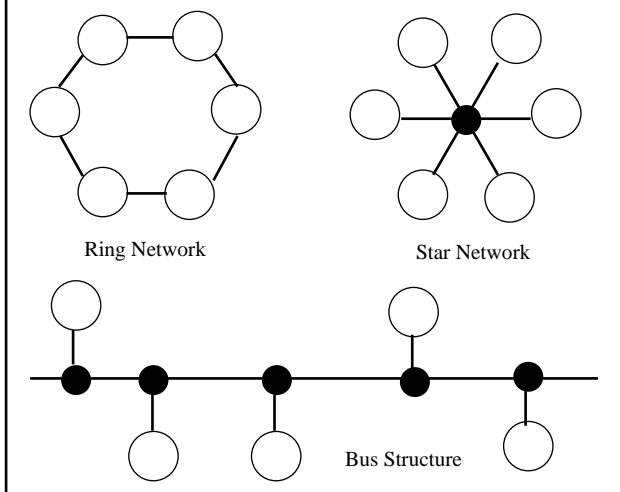

Point-to-point logical topologies are common in today's customer premises installations. Two nodes requiring direct communication are directly linked by the fibers, normally a fiber pair (one to transmit, one to receive). Common point-to-point applications include: computer channel extensions, terminal multiplexing, and video transmission.

An extension of the point-to-point is the logical star. This is a collection of point-to-points, all with a common node which is in control of the communications system. Common applications include: switches, such as a PBX, and mainframe computers.

The ring structure has each node connected serially with the one on either side of it. Messages flow from node to node in one direction only around the ring. Examples of ring topologies are: FDDI and IBM's token ring.

To increase ring survivability in case of a node failure, a counter-rotating ring is used. This is where two rings are transmitting in opposite directions. It requires two fiber pairs per node rather than the one pair used in a simple ring. FDDI utilizes a counter-ring topology.

The logical bus structure is supported by emerging standards, specifically IEEE 802.3. All nodes share a common line. Transmission occurs in both directions on the common line rather than in one direction as on a ring. When one node transmits, all the other nodes receive the transmission at approximately the same time. The most popular systems requiring a bus topology are Ethernet, and MAP, or Manufacturing Automation Protocol.

### COUPLER BASICS

A coupler is an optical device that combines or splits signals travelling on optical fibers. A port is an input or output point for light; a coupler is a multiport device.

A coupler is passive and bidirectional. Because the coupler is not a perfect device, excess losses can occur.

These losses within fibers are internal to the coupler and occur from scattering, absorption, reflections, misalignments, and poor isolation. Excess loss does not include losses from connectors attaching fibers to the ports. Further, since most couplers contain an optical fiber at each port, additional loss can occur because of diameter and NA mismatches between the coupler port and the attached fiber.

### WAVELENGTH-DIVISION MULTIPLEXING (WDM)

Multiplexing is a method of sending several signals over a line simultaneously. Wavelength-division multiplexing (WDM) uses different wavelengths to multiplex two or more signals.

Transmitters operating at different wavelengths can each inject their optical signals into an optical fiber. At the other end of the link, the signals can again be discriminated and separated by wavelength. A WDM coupler serves to combine separate wavelengths onto a single fiber or to split combined wavelengths back into their component signals.

Two important considerations in a WDM device are *crosstalk* and *channel separation*. Both are of concern mainly in the receiving or demultiplexing end of the system.

### Crosstalk

Crosstalk refers to how well the demultiplexed channels are separated. Each channel should appear only at its intended port and not at any other output port. The crosstalk specification expresses how well a coupler maintains this port-to-port separation. Crosstalk, for example, measures how much of an 820 nm wavelength appears at the 1300 nm port. For example: a crosstalk of 20 dB means that one percent of the signal appears at the unintended port.

## SECTION 2—FIBER-OPTIC BASICS

---

### Channel Separation

Channel separation describes how well a coupler can distinguish wavelengths. In most couplers, the wavelengths must be widely separated, such as 820 nm and 1300 nm. Such a device will not distinguish between 1290 nm and 1310 nm signals.

WDM allows the potential information-carrying capacity of an optical fiber to be increased significantly.

The bandwidth-length product used to specify the information-carrying capacity of a fiber applies only to a single channel—in other words, to a signal imposed on a single optical carrier.

### OPTICAL SWITCH

It is sometimes desirable to couple light from one fiber to one of two fibers, but not to both. A passive coupler (described earlier) does not allow such a choice. The division of light is always the same. An optical switch, however, does allow such a choice. It is analogous to an electrical switch, since it permits one of two circuit paths to be chosen, depending on the switch setting.

When used in a ring network, however, failure of a single terminal will shut down the entire network. The fiber-optic bypass switch overcomes this problem. Two settings on this switch permit the light signal to be transmitted to the terminal receiver or to bypass the terminal and continue on the ring to the next terminal. A directional coupler after the switch must also be used in conjunction with the switch.

The switch uses a relay arrangement to move the fiber between positions. A switch can be constructed so that it automatically switches to the bypass position if the power is removed, either from turning off the terminal intentionally or from unexpected disruption. The result is a certain degree of “fail-safe” operation.

The drawback to these switches is the difficulty of manufacturing low loss switches. Maintaining alignment on moving parts and over repeated switchings compounds the already difficult task of holding the tight tolerances imposed by the need for precise alignment in fiber optics.

For this reason and many others, great care should be exercised when selecting the manufacturer of the fiber-optic system for your application.

## SECTION 3—REFERENCES

### TABLES

**TABLE A—FIBER SPECIFICATIONS**

<b>Core diameter (in <math>\mu</math>)</b>	8	50	62.5	85	100
<b>Cladding diameter (in <math>\mu</math>)</b>	125	125	125	125	140
<b>Numerical Aperture (NA)</b>	0.11	0.20	0.29	0.26	0.30
<b>Attenuation (dB/km)</b> 850nm 1300nm 1550nm	N/A .5 .3	3 1.75 N/A	4 2 N/A	5 4 N/A	6 5 N/A
<b>Bandwidth: (MHz/km)</b> 850nm 1300nm	N/A N/A	600 750	230 500	200 300	100 300
<b>Primary Coating Layer (in <math>\mu</math>)</b>	250	250.900	250.900	250.900	250.900

**TABLE B—CABLE COMPONENTS**

<b>Component</b>	<b>Purpose</b>	<b>Material</b>
Buffer Jacket	Protects fiber from moisture, chemicals and mechanical stresses that are placed on cable during installation, splicing, and during its lifetime.	Halar; Polyester PUR filling compound.
Central Member	Facilitates stranding; allows cable flexing; provides temperature stability; prevents buckling.	Steel or fiberglass epoxy; PE overcoat.
Strength Member	Primary tensile loading bearing member.	Synthetic yarns (e.g., Kevlar).
Cable Jacket	Contains and protects cable core from scuff, impact crush, moisture, chemicals. Flame retardant.	Extruded PUR, PVC, PE, Teflon.
Armoring (Buried Cable)	Protects from rodent attack and crushing forces.	Corrugated steel tape.

## SECTION 3—REFERENCES

**TABLE C—CABLE COMPARISON (LOOSE TUBE TO TIGHT TUBE)**

Loose Tube	Features	Tight Tube
Heavier	<b>Weight</b>	Lighter
Larger	<b>Size</b>	Smaller
Larger	<b>Diameter</b>	Smaller
Less	<b>Microbending</b>	Greater
Yes	<b>Pressurization</b>	No
Less	<b>Ruggedness</b>	More
Better	<b>Tensile Loading</b>	Worse

**TABLE D—PROPERTIES OF JACKET MATERIALS**

	PVC	Low-Density Polyethylene	Cellular Polyethylene	High-Density Polyethylene	Poly-propylene	Poly-urethane	Nylon	Teflon
Oxidation Resistance	E	E	E	E	E	E	E	O
Heat Resistance	G-E	G	G	E	E	G	E	O
Oil Resistance	F	G	G	G-E	F	E	E	O
Low-Temperature Flexibility	P-G	G-E	E	E	P	G	G	O
Weather, Sun Resistance	G-E	E	E	E	E	G	E	O
Ozone Resistance	E	E	E	E	E	E	E	E
Abrasion Resistance	F-G	F-G	F	E	F-G	O	E	E
Electrical Properties	F-G	E	E	E	E	P	P	E
Flame Resistance	E	P	P	P	P	F	P	O
Nuclear Radiation Resistance	G	G	G	G	F	G	F-G	P
Water Resistance	E	E	E	E	E	P-G	P-F	E
Acid Resistance	G-E	G-E	G-E	G-E	E	F	P-F	E
Alkali Resistance	G-E	G-E	G-E	G-E	E	F	E	E
Gasoline, Kerosene, etc. (Aliphatic Hydrocarbons) Resistance	P	P-F	P-F	P-F	P-F	G	G	E
Benzol, Toluol, etc., (Aromatic Hydrocarbons) Resistance	P-F	P	P	P	P-F	P	G	E
Degreaser Solvents (Halogenated Hydrocarbons) Resistance	P-F	P	P	P	P	P	G	E
Alcohol Resistance	G-E	E	E	E	E	P	P	E

P = poor      F = fair      G = good      E = excellent      O = outstanding

These ranges are based on average performance of general-purpose compounds. Any given property can usually be improved by the use of selective compounding.

## SECTION 3—REFERENCES

**TABLE E — CABLE SELECTION**

The following questions should be addressed when selecting the cable for your requirement:

Construction:     Hybrid     All Dielectric     Metal Strength Members     Other \_\_\_\_\_

Jacket Material:  PVC     Polyurethane     Polyethylene     Other \_\_\_\_\_

Environmental Considerations:  Water blocking compounds required.     Rodent Protection

Flame Retardant     Abrasion Resistant     Nuclear Radiation Resistant     Other \_\_\_\_\_

Fiber Features:     Single-mode     Multimode

Numerical Aperture \_\_\_\_\_    Number of fibers \_\_\_\_\_

Core size \_\_\_\_\_    Cladding OD \_\_\_\_\_

Loss (per/km) \_\_\_\_\_    Bandwidth (MHz/km) \_\_\_\_\_

**TABLE F — SOURCE CHARACTERISTICS**

Characteristic	LED	Laser
Output power	Lower	Higher
Speed	Slower	Faster
Output pattern (NA)	Higher	Lower
Spectral width	Wider	Narrower
Single-mode compatibility	Wider	Narrower
Ease of use	Easier	Harder
Cost	Lower	Higher

**TABLE G — INTRINSIC LOSS FACTORS**

Type of Variation	Tolerance
Core diameter (50 $\mu$ m)	$\pm 3\mu$ m
Cladding diameter (125 $\mu$ m)	$\pm 3\mu$ m
Numerical aperture (0.260)	$\pm 0.015$
Concentricity	$\leq 3\mu$ m
Core ovality	$\geq 0.98$
Cladding ovality	$\geq 0.98$

## SECTION 3—REFERENCES

---

### GLOSSARY OF TERMS

<b>Absorption</b>	That portion of attenuation resulting from conversion of optical power to heat.
<b>AM</b>	A transmission technique in which the amplitude of the carrier is varied in accordance with the signal.
<b>American National Standards Institute (ANSI)</b>	The coordinating organization for voluntary standards in the United States.
<b>Amplitude Modulation</b>	See AM.
<b>Analog</b>	A format that uses continuous physical variables such as voltage amplitude or frequency variations to transmit information.
<b>Angular Misalignment</b>	A loss of optical power caused by deviation from optimum alignment of fiber-to-fiber or fiber-to-waveguide.
<b>APD</b>	See avalanche photodiode.
<b>Application Specific Integrated Circuit (ASIC)</b>	An IC designed for specific applications; specifically a gate array or a full custom chip. See Integrated Circuit.
<b>Aramid Yarn</b>	Strength element used in cable to provide support and additional protection of the fiber bundles. See Kevlar.
<b>Armoring</b>	Additional protection between jacketing layers to provide protection against severe outdoor environments. Usually made of plastic-coated steel, and may be corrugated for flexibility.
<b>ASCII</b>	American Standard Code for Information Interchange.
<b>ASIC</b>	See Application Specific Integrated Circuit
<b>Asynchronous Transfer Mode (ATM)</b>	A connection-type transmission mode carrying information organized into blocks (header plus information field); it is asynchronous in the sense that recurrence of blocks depends on the required or instantaneous bit rate. Statistical and deterministic values have been proposed that correspond respectively to the packet and circuit values defined for information transfer mode.
<b>ATM</b>	See Asynchronous Transfer Mode.
<b>Attenuation Coefficient</b>	The rate of optical power loss with respect to distance along the fiber, usually measured in decibels per kilometer (dB/km) at a specific wavelength. The lower the number, the better the fiber's attenuation. Typical multimode wavelengths are 850 and 1300 nanometers (nm); single-mode at 1310 and 1550 nm.
<b>Attenuation</b>	The decrease in signal strength along a fiber-optic waveguide caused by absorption and scattering. Attenuation is usually expressed in dB/km.
<b>Attenuator</b>	A device that reduces the optical signal by inducing loss.
<b>Avalanche Photodiode (APD)</b>	A photodiode that exhibits internal amplification of photocurrent through avalanche multiplication of carriers in the junction region.

## SECTION 3—REFERENCES

---

<b>Backbone wiring</b>	That portion of the premises telecommunication wiring which provides interconnections between telecommunications closets, equipment rooms, and network interfaces. The backbone wiring consists of the transmission media (fiber optic cable), main and intermediate cross-connects, and terminations for the telecommunications closets, equipment rooms, and network interfaces. The backbone wiring can be further classified as interbuilding backbone (wiring between buildings), or intrabuilding backbone (wiring within a building).
<b>Bandwidth</b>	The range of frequencies within which a waveguide or terminal device can transmit data.
<b>Baseband</b>	A method of communication in which a signal is transmitted at its original frequency without being impressed on a carrier.
<b>Baud</b>	A unit of signaling speed equal to the number of signal symbols per second which may or may not be equal to the data rate in bits per second.
<b>Beamsplitter</b>	An optical device, such as a partially reflecting mirror, that splits a beam of light into two or more beams and that can be used in fiber optics for directional couplers.
<b>Bend or Bending Loss</b>	See Microbending or Macrobending. A form of increased attenuation in a fiber caused by bending a fiber around a restrictive curvature (a macrobend) or from minute distortions in the fiber (microbends).
<b>Bend Radius</b>	See Cable Bend Radius.
<b>BER</b>	See Bit-Error Rate.
<b>Biphase-M Code</b>	A modulation code where each bit period begins with a change of level. For a 1, an additional transition occurs in midperiod. For a 0, no additional change occurs. Thus, a 1 is at both high and low during the bit period. A 0 is either high or low, but not both, during the entire bit period.
<b>BISDN</b>	See broadband integrated services digital network.
<b>Bit-Error Rate (BER)</b>	The fraction of bits transmitted that are received incorrectly.
<b>Bit</b>	The smallest unit of information upon which digital communications are built; also, an electrical or optical pulse that carries this information. A binary digit.
<b>Breakout Cable</b>	A tight-buffer cable design that is used with individual strength members for each fiber, which allows for direct termination to the cable without using breakout kits or splice panels. One can “break out” several fibers at any location, routing the other fibers elsewhere.
<b>Broadband ISDN (BISDN)</b>	A proposed form of the integrated services digital network (ISDN) which will carry digital transmission at rates equal to or greater than the T-1 rate (1.544 megabits per second). Proposed BISDN standards packetize information (voice, data, video) into fixed-length cells for transmission over synchronous optical networks.
<b>Broadband</b>	A method of communication in which the signal is transmitted by being impressed on a higher frequency carrier.

## SECTION 3—REFERENCES

---

<b>Buffer Coating</b>	A protective layer, such as an acrylic polymer, applied over the fiber cladding for protective purposes.
<b>Buffer Tube</b>	A hard plastic tube having an inside diameter several times that of a fiber that holds one or more fibers.
<b>Buffer</b>	A protective coating applied directly to the fiber such as a coating, an inner jacket, or a hard tube.
<b>Bus Network</b>	A network topology in which all terminals are attached to a transmission medium serving as a bus.
<b>Byte</b>	A binary string (usually of 8 bits) operated as a unit.
<b>Cable Assembly</b>	Fiber-optic cable that has connectors installed on one or both ends. General use of these assemblies includes the interconnection of fiber-optic systems and opto-electronic equipment. If connectors are attached to only one end of a cable, it is known as a pigtail. If connectors are attached to both ends, it is known as a jumper.
<b>Cable Bend Radius</b>	This term implies that the cable is experiencing a tensile load. Free bend implies a smaller allowable bend radius since it is at a condition of no load.
<b>Cable</b>	One or more optical fibers enclosed within protective covering(s) and strength members.
<b>CCIT</b>	See Consultative Committee on International Telegraph and Telephone.
<b>Central Member</b>	The center component of a cable, it serves as an antibuckling element to resist temperature-induced stresses. Sometimes serves as a strength element. The central member is composed of steel, fiberglass, or glass-reinforced plastic.
<b>Channel Separation</b>	This specification describes how well a coupler can distinguish wavelengths.
<b>Channel</b>	A communications path or the signal sent over that channel. Through multiplexing several channels, voice channels can be transmitted over an optical channel.
<b>Chromatic Dispersion</b>	This condition occurs because different wavelengths of light travel at different speeds. No transmitter produces a pure light source of only one wavelength. Instead, sources produce a range of wavelengths around a center wavelength. These wavelengths travel at slightly different speeds, resulting in pulse spreading that increases with distance.
<b>Chrominance Signal</b>	The portion of the NTSC color-television signal that contains the color information.
<b>Cladding</b>	The lower index-of-refraction material that surrounds the core of an optical fiber, causing the transmitted light to travel down the core.
<b>Cleavers</b>	Tools which allow the operator to break or scribe the fiber with a 90 degree endface perpendicular to the axis of the fiber with little surface damage or irregularities to the fiber.
<b>Coating</b>	Thermoplastic layer directly adhered to cladding to give flexibility and strength.

## SECTION 3—REFERENCES

---

<b>Coaxial Cable</b>	A central conductor surrounded by an insulator, which in turn is surrounded by a tubular outer conductor, which is covered by more insulation.
<b>Codec</b>	Coder-decoder. Coder converts analog signals to digital for transmission; decoder converts digital signal to analog at other end.
<b>Coherence</b>	Lasers emit a parallel beam which is nearly coherent (as opposed to a LED which would be considered incoherent). The degree of coherence is a better phrasing.
<b>Complementary Metal-Oxide Semiconductor (CMOS)</b>	A logic family used in transmitters and receivers. Potentially a replacement for TTL.
<b>Conduit</b>	Pipe or tubing through which cables can be pulled or housed.
<b>Connector</b>	A mechanical or optical device that provides a demountable connection between two fibers or a fiber and a source or detector, connecting transmitters, receivers, and cables into working links. Commonly used connectors include Biconic, ST, and SMA.
<b>Consultative Committee on International Telegraph and Telephone (CCIT)</b>	A component division of the International Telecommunications (ITU) that attempts to establish international telecommunications standards by issuing recommendations which express, as closely as possible, an international consensus.
<b>Core</b>	The light-conducting central portion of an optical fiber composed of a material with a higher index of refraction than the cladding.
<b>Coupler</b>	An optical device that combines or splits signals from optical fibers.
<b>Crosstalk</b>	Each channel should appear only at its intended port and not at any other output port. The crosstalk specification expresses how well a coupler maintains this port-to-port separation. Crosstalk, for example, measures how much of the 820 nm wavelength appears at the 1300 nm port. A crosstalk of 20 dB would mean that 1 percent of the signal appears at the unintended port.
<b>Cutback Method</b>	A technique of measuring optical fiber attenuation by measuring the optical power at two points at different distances from the test source.
<b>Cutoff Wavelength</b>	In single-mode fiber, the wavelength below which the fiber ceases to be single mode.
<b>Dark Current</b>	The thermally induced current that exists in a photodiode in the absence of incident optical power; the lowest level of thermal noise.
<b>Data Rate</b>	The number of bits of information in a transmission system, expressed in bits per second (bps) and which may or may not be equal to the signal or baud rate.
<b>dB</b>	See Decibel.
<b>dBm</b>	Decibel referenced to a milliwatt.
<b>dBμ</b>	Decibel referenced to a microwatt.

## SECTION 3—REFERENCES

---

<b>Decibel (dB)</b>	A unit of measurement indicating relative power on a logarithmic scale. Often expressed in reference to a fixed value, such as dBm (1 milliwatt) or dB $\mu$ (1 microwatt).
<b>Detector</b>	The receiving photodiode.
<b>Diameter Mismatch Loss</b>	The loss of power at a joint that occurs when the transmitting half has a diameter greater than the diameter of the receiving half. The loss occurs when coupling light from a source to fiber, from fiber to fiber, or from fiber to detector.
<b>Dichroic Filter</b>	An optical filter that transmits light selectively according to wavelength.
<b>Dielectric</b>	Nonmetallic and, therefore, nonconductive. Glass fibers are considered to be dielectric. A dielectric cable contains no metallic components.
<b>Differential Gain</b>	The amplitude change, usually of the 3.58-MHz color subcarrier, caused by the overall circuit as the luminance is varied from blanking to white level. It is expressed in percent or in decibels.
<b>Diffraction Grating</b>	An array of fine, parallel, equally spaced reflecting or transmitting lines that mutually enhance the effects of diffraction to concentrate the diffracted light in a few directions determined by the spacing of the lines and by the wavelength of the light.
<b>Diffraction</b>	An array of fine, parallel reflecting lines caused by the interaction of the wave and an object. Diffraction causes deviation of waves from their paths.
<b>Digital</b>	A data format that uses two physical levels to transmit information corresponding to 0s and 1s. A discrete or discontinuous signal.
<b>Dispersion</b>	The temporal spreading of a light signal in an optical waveguide, which is caused by light signals traveling at different speeds through a fiber either due to modal or chromatic effects.
<b>Duplex Cable</b>	A two-fiber cable suitable for duplex transmission.
<b>Duplex Transmission</b>	Transmission in both directions, either one direction at a time (half duplex) or both directions simultaneously (full duplex).
<b>ECL</b>	See Emitter Coupled Logic.
<b>EIA</b>	Electronic Industries Association. A standards association that publishes test procedures.
<b>Elastomeric Splice</b>	One that is made from a plastic material (elastic) formed into a mold. The mold allows for a hole to be made and the elastomeric material is flexible enough so that fibers can be positioned and firm enough so the fibers are retained during handling and splicing without the need for repositioning equipment.
<b>Electromagnetic Pulses (EMP)</b>	Although exhibiting great resistance to electromagnetic pulses (radiation), fiber optics are not totally immune to the effects of EMP. Special optical fiber can be purchased for usage in applications where EMP may be a factor.

## SECTION 3—REFERENCES

---

<b>Electro-Optical Switch</b>	A device that allows the routing of optical signals (under electronic control), without an intermediary conversion to electronic signals.
<b>Electromagnetic Interference (EMI)</b>	Any electrical or electromagnetic interference that causes undesirable response, degradation, or failure in electronic equipment. Optical fibers neither emit nor receive EMI.
<b>Electromagnetic Spectrum</b>	An infrared region invisible to the human eye.
<b>EMD</b>	See Equilibrium Mode Distribution.
<b>EMI</b>	Electromagnetic interference, like RFI, is something that does not affect fiber optic. See Electromagnetic Interference.
<b>Emitter Coupled Logic (ECL)</b>	A common digital logic used in fiber-optic transmitters and receivers that is faster than TTL.
<b>EMP</b>	See Electromagnetic Pulses.
<b>Equilibrium Mode Distribution (EMD)</b>	The steady modal state of a multimode fiber in which the relative power distribution among modes is independent of fiber length.
<b>Ethernet</b>	Ethernet is a bus network LAN using CSMA/CD. Originally created by Xerox Corporation, Digital Equipment Corporation, and Intel Corporation, Ethernet was designed to use coaxial cable at data rates up to 10 Mbps.
<b>Excess Loss</b>	In a fiber-optic coupler, the optical loss from that portion of light that does not emerge from the nominally operational ports of the device.
<b>Extrinsic Loss</b>	In a fiber interconnection, that portion of loss that is not intrinsic to the fiber, but is related to imperfect joining, which may be caused by the connector or splice.
<b>FDDI</b>	See Fiber Distributed Data Interface.
<b>FDM</b>	See frequency division multiplexing.
<b>Ferrule</b>	A mechanical fixture, generally a rigid tube, used to confine and align the polished or cleaved end of a fiber in a connector. Generally associated with fiber-optic connectors.
<b>Fiber Distributed Data Interface (FDDI)</b>	A standard for a 100 Mbit/sec fiber-optic local area network.
<b>Fiber-Optic Link</b>	A transmitter, receiver, and cable assembly that can transmit information between two points.
<b>Fiber</b>	Thin filament of glass. An optical waveguide consisting of a core and a cladding which is capable of carrying information in the form of light.
<b>FM</b>	See frequency modulation.
<b>Four-Wire Circuit</b>	A two-way communication circuit using two paths, arranged so signals are transmitted one direction on one path, and in the opposite direction on the other path.

## SECTION 3—REFERENCES

---

<b>Frame</b>	A linear set of transmitted bits which define a basic transport element. In synchronous transmission, the frames are defined by rigid timing protocols between the transmitting and receiving ends. In asynchronous transmission, frames are defined by bits embedded within the frame, either at the beginning of the frame or at the beginning and end of the frame.
<b>Frequency Division Multiplexing (FDM)</b>	A method of deriving two or more simultaneous continuous channels from a transmission medium connecting two points by assigning separate portions of the available frequency spectrum to each of the individual channels being shifted to and allotted a different frequency band.
<b>Frequency Modulation</b>	A method of transmission in which the carrier frequency varies in accordance with the signal.
<b>Fresnel Reflection Loss</b>	Reflection losses at ends of fibers caused by differences in refractive index between the core glass and the immersion medium due to Fresnel reflections.
<b>Fresnel Reflection</b>	The reflection that occurs at the planar junction of two materials having different refractive indices; Fresnel reflection is not a function of the angle of incidence.
<b>Full Duplex</b>	See Duplex Transmission.
<b>Fusion Splice</b>	The joining together of glass fibers by melting them together using an electric arc. This is a permanent method considered to be highly reliable and with the lowest loss.
<b>Fusion Splicer</b>	An instrument that permanently bonds two fibers together by heating and fusing them.
<b>Gap Loss</b>	Loss resulting from the end separation of two axially aligned fibers.
<b>Gigahertz (GHz)</b>	A unit of frequency that is equal to one billion cycles per second.
<b>Graded Index</b>	Optical fiber in which the refractive index of the core is in the form of a parabolic curve, decreasing toward the cladding. This process tends to speed up the modes. Light is gradually refocused by refraction in the core. The center, or axial, mode is the slowest. (See Step Index.)
<b>Ground Loop Noise</b>	Noise that results when equipment is grounded at ground points having different potentials and thereby created an unintended current path. The dielectric of optical fibers provide electrical isolation that eliminated ground loops.
<b>Half Duplex</b>	See Duplex Transmission.
<b>HDTV</b>	See High-Definition Television.
<b>High-Definition Television (HDTV)</b>	A television format offering resolution and picture quality comparable to 35-mm motion picture film. A television standard under development by CCIR.
<b>Hub</b>	An interconnection point for high-speed interoffice trunks. Multiplexed on high-capacity (typically fiber), traffic is routed through the hub to its destination.
<b>Hybrid Optical Cable</b>	A unique type of cable designed for multipurpose applications where both optical fiber and twisted pair wires are jacketed together for situations where both technologies are presently used.

## SECTION 3—REFERENCES

---

<b>IC</b>	See integrated circuit.
<b>IEEE</b>	Institute of Electrical and Electronics Engineering.
<b>Index Matching Fluid</b>	A fluid whose index of refraction equals that of the fiber's core. Used to reduce Fresnel reflections at fiber ends.
<b>Index of Refraction</b>	The ratio of light velocity in a vacuum compared to its velocity in the transmission medium is known as index of refraction. Light travels in a vacuum through space at 186,291 miles per second. Divided by its speed through optical glass (122,372 miles per second), the calculation for its index of refraction is 1.51.
<b>Insertion Loss</b>	The method for specifying the performance of a connector or splice.
<b>Integrated Circuit (IC)</b>	A complete electronic device including transistors, resistors, capacitors, plus all wiring and interconnections fabricated as a unit on a single chip.
<b>Integrated Services Digital Network (ISDN)</b>	A set of international technical standards that permit the transmission of voice, data, facsimile, slow-motion video, and other signals over the same pair of wires or optical fibers.
<b>ISDN</b>	See Integrated Services Digital Network.
<b>Jacket</b>	The outer, protective covering of fiber-optic cable.
<b>Kevlar®</b>	Strength element used in cable to provide support and additional protection of the fiber bundles Kevlar is the registered trademark of E. I. DuPont de Nemours. See Aramid Yarn.
<b>KPSI</b>	A unit of tensile force expressed in thousands of pounds per square inch. Usually used as the specification for fiber proof test, i.e., 50 KPSI.
<b>LAN</b>	See Local Area Network.
<b>Laser</b>	An acronym for Light Amplification by Stimulated Emission of Radiation. A light source used primarily in single-mode fiber-optic links. Center wavelengths of 1300 nm are most common, although some operate at 1550 nm. Lasers have a very narrow spectral width compared to LEDs and average power of a laser source is also much higher than that of LEDs. Modulation frequencies exceeding 1 GHz are possible.
<b>Laser Diode</b>	An electro-optic semiconductor device that emits coherent light with a narrow range of wavelengths, typically centered around 1310 nm or 1550 nm.
<b>Laser Diode (Source)</b>	Sometimes called the semiconductor diode. A laser in which the lasing occurs at the junction of n-type and p-type semiconductor materials.
<b>LED</b>	See Light Emitting Diode.
<b>Light-Emitting Diode (LED)</b>	A semiconductor that emits incoherent light when forward biased. Used primarily with multimode optical communications systems. Center wavelengths are typically 850 nm or 1300 nm and average power levels are <10 dB to <30 dB.

## SECTION 3—REFERENCES

---

<b>Local-Area Network (LAN)</b>	A geographically limited communications network intended for the local transport of data, video, and voice. A communication link between two or more points within a small geographic area, such as between two buildings.
<b>Loose Tube Cable</b>	Cable design featuring fibers placed into a cavity which is much larger than the fiber with its initial coating, such as a buffer tube, envelope, or slotted core. This allows the fiber to be slightly longer than its confining cavity allowing movement of the fiber within the cable to provide strain relief during cabling and field placing operations.
<b>Loss per Wavelength</b>	Just as the speed of light slows when traveling through glass, each infrared wavelength is transmitted differently within the fiber. Therefore, attenuation or optical power loss, must be measured in specific wavelengths.
<b>Loss Windows</b>	Fiber-optic transmission is typically at the 830—1300 nm region for multimode fiber; and 1300—1550 nm region for single-mode. The history of the usage comes from the availability of sources and detectors and their operating characteristics due to the absorption effects at different wavelengths.
<b>Loss</b>	The amount of a signal's power, expressed in dB, that is lost in connectors, splices, or fiber defects.
<b>Lossy</b>	In real time audio transmission, denotes compression system used to transmit fixed input bandwidth and fixed output bandwidth—primary aim of lossy audio compression is to ensure that any corruption of the original data is inaudible.
<b>Luminance Signal</b>	The portion of the NTSC color-television signal that contains the brightness information.
<b>Manchester Code</b>	A modulation code that uses a level transition in the middle of each bit period. For a binary 1, the first half of the period is high, and the second half is low. For a binary 0, the first half is low, and the second half is high.
<b>Margin</b>	Allowance for attenuation in addition to that explicitly accounted for in system design.
<b>Material Dispersion</b>	Dispersion resulting from the different velocities of each wavelength in an optical fiber.
<b>Mb</b>	See Megabit.
<b>Mechanical Splice</b>	The joining together of glass fibers usually by a glass capillary. This is a permanent method considered to be low in loss and offers good reliability.
<b>Megabit (Mb)</b>	One million (1,000,000) binary digits, or bits.
<b>Megahertz (MHz)</b>	A unit of frequency that is equal to one million cycles per second.
<b>MFD</b>	See Mode Field Diameter.
<b>Micrometer (µm)</b>	One millionth of a meter. 10 <sup>-6</sup> meter. Typically used to express the geometric dimension of fibers.

## SECTION 3—REFERENCES

---

<b>Miller Code</b>	A modulation code where each 1 is encoded by a level transition in the middle of the bit period. A 0 is represented either by no change in level following a 1 or by a change at the beginning of the bit period following a 0.
<b>Mixing Rod</b>	Relatively large, rectangular or circular waveguide.
<b>Modal Dispersion</b>	Dispersion resulting from the different transit lengths of different propagating modes in a multimode optical fiber.
<b>Mode Coupling</b>	The transfer of energy between modes. In a fiber, mode coupling occurs until EMD is reached.
<b>Mode Field Diameter (MFD)</b>	The diameter of the one mode of light propagating in a single-mode fiber. The mode field diameter replaces core diameter as the practical parameter in a single-mode fiber.
<b>Mode Filter</b>	A device that removes higher-order modes to simulate equilibrium modal distribution.
<b>Mode Scrambler</b>	A device that mixes modes to uniform power distribution.
<b>Mode Stripper</b>	A device that removes cladding modes.
<b>Mode</b>	A term used to describe a light path through a fiber, as in multimode or single mode. A single electromagnetic field pattern within an optical fiber.
<b>Modulation</b>	Coding of information onto the carrier frequency. This includes amplitude, frequency, or phase modulation techniques.
<b>Muldem</b>	Short for multiplexer-demultiplexer. This device combines or separates lower level digital signals to a higher level signal.
<b>Multimode Fiber</b>	An optical fiber that has a core large enough to propagate more than one mode of light (typical core/cladding sizes are 50/125, 62.5/125, and 100/140 micrometers).
<b>Multiplex</b>	To put two or more signals into a single data stream.
<b>NA</b>	See numerical aperture.
<b>Nanometer (nm)</b>	A unit of measurement equal to one billionth of a meter. $10^{-9}$ meters. Typically used to express the wavelength of light.
<b>NEC</b>	National Electrical Code. Defines building flammatory requirements for indoor cables.
<b>Network Interface</b>	The point of interconnection between the outside service carrier's telecommunication facilities and the premises wiring and equipment on the end user's facilities.
<b>Nonreturn to Zero (NRZ)</b>	A modulation code that is similar to "normal" digital data. The signal is high for a 1 and low for a 0. For a string of 1s, the signal remains high and for a string of 0s it remains low. Thus, the level changes only when the data level changes.
<b>NRZ</b>	See Nonreturn to Zero code above.

## SECTION 3—REFERENCES

---

<b>NRZI (nonreturn-to-zero, inverted) Code</b>	A modulation code where 0 is represented by a change in level, and a 1 is represented by no change in level. Thus, the level will go from high to low or from low to high for each 0. It will remain at its present level for each 1. An important thing to notice here is that there is no firm relationship between 1s and 0s of data and the highs and lows of the code. A binary 1 can be represented by either a high or a low, as can a binary 0.
<b>Numerical Aperture (NA)</b>	The mathematical measure of the fiber's ability to accept lightwaves from various angles and transmit them down the core. A large difference between the refractive indices of the core and the cladding means a larger numerical aperture (NA). The larger the NA, the more power that can be coupled into the fiber. For short distances this is advantageous; however, for transmitting long distances the dispersion or pulse spreading is too great.
<b>OLTS</b>	See Optical Loss Test Set.
<b>Optical Amplifier or Optical Repeater</b>	A device that receives low-level optical signals from an optical fiber, amplifies the optical signal, and inserts it into an outbound optical fiber, without converting the signal to electrical pulses as an intermediary step.
<b>Optical Coupler</b>	An optical device used to distribute light signals between multiple input and output fibers.
<b>Optical Fiber or Optical Waveguide</b>	A glass or plastic fiber that has the ability to guide light along its axis.
<b>Optical Loss Test Set (OLTS)</b>	A source and power meter combined to measure attenuation or loss.
<b>Optical Time Domain Reflectometry (OTDR)</b>	A method of evaluating optical fibers based on detecting backscattered (reflected) light. Used to measure fiber attenuation, evaluate splice and connector joints, and locate faults.
<b>Output Pattern</b>	The output pattern of the light is important to understand. As light leaves the chip, it spreads out. Only a portion actually couples into the fiber. A smaller output pattern allows more light to be coupled into the fiber. A good source should have a small emission diameter and a small NA. The emission diameter defines how large the area of emitted light is. The NA defines at what angles the light is spreading out. If either the emitting diameter or the NA of the source is larger than those of the receiving fiber, some of the optical power will be lost.
<b>Output Power</b>	The optical power emitted at a specified drive current. An LED emits more power than a laser operating below the threshold. Above the lasing threshold, the laser's power increases dramatically with increases in drive current. In general, the output power of a device is in decreasing order: laser, edge-emitting LED, surface-emitting LED.
<b>Packet Assembler/ Disassembler (PAD)</b>	A communications computer defined by the CCITT as the interface between asynchronous terminals and a packet switching network.
<b>Packet Switching</b>	(1) A mode of data transmission in which messages are broken into smaller increments called packets, each of which is routed independently to the destination. (2) The process of routing and transferring data by means of addressed packets, in which a channel is occupied only during the transmission of the packet; the channel is then available for other packets.

## SECTION 3—REFERENCES

---

<b>Packet</b>	A group of binary digits, including data and call-control signals, switched as a composite whole.
<b>PAD</b>	See Packet Assembler/Disassembler.
<b>PAL</b>	See Phase Alternation Line.
<b>PCM</b>	See Pulse Code Modulation.
<b>PCS</b>	See Plastic Clad Silica.
<b>PE</b>	Abbreviation used to denote polyvinyl chloride. A type of plastic material used to make cable jacketing.
<b>Phase Alternation Line (PAL)</b>	The TV color standard used in Europe and Australia.
<b>Photodetector</b>	An optoelectronic transducer such as a pin photodiode or avalanche photodiode.
<b>Photodiode</b>	A semiconductor device that converts light to electrical current.
<b>Photon</b>	A quantum of electromagnetic energy. A “particle” of light.
<b>Photonic Switching</b>	A generic term implying the combining, switching, and routing of optical (photonic) signals without first converting them to electrical signals.
<b>Pigtail</b>	See Cable Assembly.
<b>Pn Photodiode</b>	The simplest photodiode not widely used in fiber optics. The pin and avalanche photodiodes overcome the limitations of this device.
<b>Pin Photodiode</b>	A photodiode having a large intrinsic layer sandwiched between p-type and n-type layers.
<b>Plastic-Clad Silica (PCS)</b>	A step-index fiber with glass core and plastic cladding.
<b>Plenum</b>	The return or air-handling space located between a roof and a dropped ceiling. Plenum cables must meet higher NEC codes concerning smoke and resistance to flame than are applied to similar PVC or polyethylene cables without the use of metal conduit.
<b>Polarization</b>	A term used to describe the orientation of the electric and magnetic field vectors of a propagating electromagnetic wave. An electromagnetic wave theory describes in detail the propagation of optical signals (light).
<b>Power Budget</b>	Ensures that losses are low enough in a fiber-optic link to deliver the required power to the receiver.
<b>Preform</b>	A glass rod from which optical fiber is drawn.
<b>Pulse Coded Modulation (PCM)</b>	A technique in which an analog signal, such as a voice, is converted into a digital signal by sampling the signal’s amplitude and expressing the different amplitudes as a binary number. The sampling rate must be twice the highest frequency in the signal.

## SECTION 3—REFERENCES

---

<b>PVC</b>	Abbreviation used to denote polyvinyl chloride. A type of plastic material used to make cable jacketing. Typically used in riser-rated cables.
<b>PVDF</b>	Abbreviation used to denote polyvinyl fluoride. A type of material used to make cable jacketing. Typically used in plenum-rated cables.
<b>Quantum Efficiency</b>	In a photodiode, the ratio of primary carriers (electron-hole pairs) created to incident photons. A quantum efficiency of 70% means seven out of 10 incident photons create a carrier.
<b>Receiver</b>	A terminal device that includes a detector and signal processing electronics. It functions as an optical-to-electrical converter.
<b>Reflection</b>	The abrupt change in direction of a light beam at an interface between two dissimilar media so that the light beam returns into the medium from which it originated its reflection, e.g., a mirror.
<b>Refraction</b>	The bending of a beam of light in transmission between two dissimilar materials or in a graded index fiber where the refractive index is a continuous function of position is known as refraction.
<b>Refractive Index</b>	A property of optical materials that relates to the speed of light in the material.
<b>Repeater</b>	A receiver and transmitter set designed to regenerate attenuated signals.
<b>Response Time</b>	The time required for a photodiode to respond to optical inputs and produce external current. Usually expressed as a rise time and a fall time.
<b>Responsivity</b>	In a photodiode, the ratio of the diode's output current to input optical power.
<b>Return to Zero (RZ)</b>	A digital modulation coding scheme where the signal level remains low for 0s. For a binary 1, the level goes high for one half of a bit period and then returns low for the remainder. For each 1 of data, the level goes high and returns low within each bit period. For a string of three 1s, for example, the level goes high for each 1 and returns to low.
<b>RFI</b>	Radio frequency interference, something that fiber is totally resistant to.
<b>Rise-Time Budget</b>	Ensures that all components meet the bandwidth/rise-time requirements of the link.
<b>Riser</b>	Application for indoor cables that pass between floors. It is normally a vertical shaft or space.
<b>RZ Code</b>	See Return-to-Zero Code.
<b>SECAM</b>	See Sequential Color and Memory (Sequential Couleurs a Memoire).
<b>Sequential Color and Memory (SECAM)</b>	The color standard used in France and the area formerly identified as the Soviet Union.
<b>Signal-to-Noise Ratio (SNR)</b>	The ratio of signal power to noise power.

## SECTION 3—REFERENCES

---

<b>Simplex Cable</b>	A term sometimes used for a single-fiber cable, not to be confused with single-mode fiber.
<b>Simplex Transmission</b>	Transmission in one direction only.
<b>Single-Mode Fiber</b>	Actually a step index fiber, single-mode fiber has the smallest core size (8 micrometers is typical) allowing only an axial mode to propagate in the core. Dispersion is very low. This fiber usually requires a laser light source.
<b>SNA</b>	See Systems Network Architecture.
<b>Snell's Law</b>	A mathematical law that states the relationship between incident and refracted rays of light: The law shows that the angles depend on the refractive indices of the two materials.
<b>SNR</b>	See Signal-to-Noise Ratio.
<b>SONET</b>	See Synchronous Optical Network.
<b>Source</b>	A transmitting LED or laser diode, or an instrument that injects test signals into fibers.
<b>Spectral Width</b>	The total power emitted by the transmitter distributed over a range of wavelengths spread about the center wavelength is the spectral width.
<b>Splice Closure</b>	A container used to organize and protect splice trays.
<b>Splice Tray</b>	A container used to organize and protect spliced fibers.
<b>Splice</b>	A permanent connection of two optical fibers through fusion or mechanical means. An interconnection method for joining the ends of two optical fibers in a permanent or semipermanent fashion.
<b>Star Coupler</b>	Optical component in fiber-optic systems which allows for the emulation of a bus topology. Also referred to as a star concentrator.
<b>Star Network</b>	A network in which all terminals are connected through a single point, such as a star coupler.
<b>Step-Index Fiber</b>	The light reflects off the core cladding boundary in a step profile. The glass has a uniform refractive index throughout the core. (See Graded Index and Single Mode.)
<b>Subscriber Loop or Local Loop</b>	The link from the telephone company central office (CO) to the home or business (customer's premises).
<b>Synchronous Optical Network (SONET)</b>	A standard for optical network elements providing modular building blocks, fixed overhead, and integrated operations channels, and flexible payload mappings.
<b>Systems Network Architecture</b>	The detailed design, including protocols, switching and transmission, that constitutes a telecommunications network.
<b>T-1</b>	The basic 24-channel 1.544 Mb/s pulse code modulation system used in the United States.

## SECTION 3—REFERENCES

---

<b>TDM</b>	See Time Division Multiplexing.									
<b>Tee Coupler</b>	A three-port optical coupler.									
<b>Thermal Noise</b>	Noise resulting from thermally induced random fluctuations in current in the receiver's load resistance.									
<b>Throughput Loss</b>	In a fiber-optic coupler, the ratio of power at the throughput port to the power at the input port.									
<b>Throughput</b>	The total useful information processed or communicated during a specified time period. Expressed in bits per second or packets per second.									
<b>Tight Buffer Cable</b>	Cable design featuring one or two layers of protective coating placed over the initial fiber coating which may be on an individual fiber basis or in a ribbon structure.									
<b>Time-Division Multiplexing (TDM)</b>	Digital multiplexing by taking one pulse at a time from separate signals and combining them in a single, synchronized bit stream.									
<b>Token Bus</b>	A network with a bus or tree topology using token passing access control.									
<b>Token Passing</b>	A method whereby each device on a local area network receives and passes the right to use the channel. Tokens are special bit patterns or packets, usually several bits in length, which circulate from node to node when there is no message traffic. Possession of the token gives exclusive access to the network for message transmission.									
<b>Token Ring</b>	A registered trademark of IBM that represents their token access procedure used on a network with a sequential or ring topology.									
<b>Topology</b>	Network topology can be centralized or decentralized. Centralized networks, or star-like networks, have all nodes connected to a single node. Alternative topology is distributed; that is, each node is connected to every other node.  Typical topology names include bus, ring, star, and tree.									
<b>Transceiver</b>	A device that embodies the characteristics of a receiver and a transmitter within one unit.									
<b>Transducer</b>	A device for converting energy from one form to another, such as optical energy to electrical energy.									
<b>Transistor-Transistor Logic (TTL)</b>	A common digital logic circuits used in a fiber-optic transmitter.									
<b>Transmitter</b>	An electronic package that converts an electrical signal to an optical signal.									
<b>Voice Circuit</b>	A circuit able to carry one telephone conversation or its equivalent; the standard subunit in which telecommunication capacity is counted. The digital equivalent is 56 kbit/sec in North America. Common voice networks are: <table><tr><td>T1</td><td>42 channels</td><td>1.544 Mbit/sec</td></tr><tr><td>T3</td><td>672 channels</td><td>45 Mbit/sec</td></tr><tr><td>T3C</td><td>1344 channels</td><td>90 Mbit/sec</td></tr></table>	T1	42 channels	1.544 Mbit/sec	T3	672 channels	45 Mbit/sec	T3C	1344 channels	90 Mbit/sec
T1	42 channels	1.544 Mbit/sec								
T3	672 channels	45 Mbit/sec								
T3C	1344 channels	90 Mbit/sec								

## SECTION 3—REFERENCES

---

<b>Waveform</b>	A graphical representation of a varying quantity. Usually, time is represented on the horizontal axis, and the current or voltage value is represented on a vertical axis.
<b>Wavelength-Division Multiplexing (WDM)</b>	Multiplexing of signals by transmitting them at different wavelengths through the same fiber. A method of multiplexing two or more optical channels separated by wavelength.
<b>Wavelength</b>	The distance between two crests of an electromagnetic waveform, usually measured in nanometers (nm).
<b>WDM</b>	See Wavelength Division Multiplexing.
<b>Zero Dispersion Wavelength</b>	Wavelength at which net chromatic dispersion of an optical fiber is zero. Arises when waveguide dispersion cancels out material dispersion.

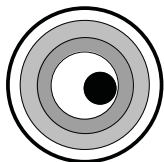
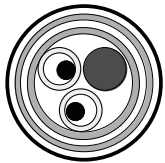
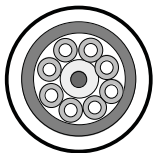

 **Fiber Options** ... *light years ahead*

---

FIBER OPTIONS, INC. / 80 Orville Drive / Bohemia / New York / 11746-2533  
516-567-8320 / 1-800-342-3748 / FAX 516-567-8322